

Certified Lift Power VAS Approved Solutions

manufactured by AUTOPSTENHOJ



Who is AUTOPSTENHOJ?

AUTOPSTENHOJ is a leading manufacturer of car lifts and part of the Italian Nexion Group. The company is based in Rheine, Westphalia, and specialises in the production and worldwide distribution of high-quality lifting technology for cars and vans.

AUTOPSTENHOJ is one of the pioneers in the market, with more than 100 years of experience in the field of lifting technology. The product portfolio includes a nearly complete range of inground and surface-mounted lifts. In addition to production and sales, AUTOPSTENHOJ also stands for strong, worldwide on-site service. The company's own customer service personnel and well-trained service technicians from its sales partners ensure maintenance and repairs at the highest level.

For many decades, the Volkswagen Group and AUTOPSTENHOJ have had a close partnership. Since then, lifts have been developed together and with the aim of meeting the VAS quality seal.

The lifts awarded the VAS quality seal stand for the highest quality, safety and efficient use in the maintenance and repair of Volkswagen Group cars and commercial vehicles.

Visit us: www.autopstenhoj.com

**Certified Lift Power
VAS Approved Solutions**

manufactured by AUTOPSTENHOJ

- [VAS 781 005A](#) | Sololift 1.35 Saa Ø 213 VW 2
- [VAS 5246A](#) | Masterlift 2.35 NxT Pv 160-220 xy VW 6
- [VAS 782 003A](#) | Masterlift 2.35 NxT Saa 260 VW 12
- [VAS 782 019A](#) | Masterlift 2.35 Combi Check-in KA 1550 VW 18
- [VAS 782 035A](#) | Biglift 2.55 Saa 230 VW..... 22
- [VAS 782 037A](#) | Biglift 2.55 Saa 265 VW 26
- [VAS 782 027A](#) | Biglift 4.55 Combii VW..... 30
- [VAS 782 049](#) | Biglift 2.65 Saaa 230 VW 34
- [VAS 782 015A](#) | Biglift 2.65 Saaa 265 VW 38
- [VAS 782 039A](#) | Maestro 35 F VW 42
- [VAS 782 005A](#) | Maestro 2.35 NxT F VW 46
- [VAS 782 023A](#) | Maestro 2.60 NxT F VW 50

This overview shows the new VAS approvals.

In addition, we have further approvals that have existed longer.

Find out more on our website at: www.autopstenhoj.com/en/freigaben/volkswagen-group.



VAS 781 005A Sololift 1.35 Saa VW

ASE78100581000

Electro-hydraulic centre-ram lift 3.5 t,
superstructure with arms



→ Perfect centre-ram lift
Reliable, low-maintenance and user-friendly!

The double telescopic swivel arms convince with a very low minimum height which even makes it possible to lift low-profile sports cars without any problems.

The internal arm locking system installed as standard reliably protects against external influences.

The strong 213 mm cylinder is designed for long-lasting functionality and further rounds off the high-quality level, which ensures low maintenance requirements.

Even in the event of a power blackout, the lift can still be lowered without any problem thanks to the pneumatic emergency lowering system. The **VAS 781 005A I Sololift 1.35 Saa VW** is perfectly completed by a control system that is both visually and technically convincing.

Standard colour:
RAL 7012

Options:
Large program of extra pads depending on type of vehicle

Installation variants:
Superstructure on floor with hydraulic pump unit in floor

Scope of delivery:
VAS 781 005A I Sololift 1.35 Saa VW
ASE78100581000

Order no.	Item no.	#	Part of the approval:
20012128-1	21215	1	Superstructure 1.35 Saa Ø50 mm
	12560	1	VW specification VAS 781 005A
	38824	1	Swivel arm hook 1100 lg
	11103	1	Document holder
20012128-2	16010	4	Lifting pad extension 50 mm - Ø50 mm 1 pc
	10306	1	Hydraulic unit SL 1.35 with integrated pump unit, stroke 1910 mm for cylinder Ø213 mm
	11063	1	Set of cables 10 m
	12034	1	Ecological hydraulic fluid 14 ltr.

Not included in the scope of approval, please order separately:

Steel cassette:
Self supporting
Standard: painted
Optional: hot-dip galvanized or plastic-coated

VAS 782 005A

Sololift

1.35 Saa VW

ASE78100581000

Technical data

Lifting capacity	3500 kg
Stroke length	1910 mm
Working height	2005 - 2084 mm
Cylinder diameter	213 mm
Lifting/ lowering time	~ 30 sec.
Foundation depth	2650 mm
Pump unit	3.0 kW
Hydraulic oil	14 l
Voltage	230/400 V / 50 Hz / 16 A

Arm superstructure

Lifting pad included in the delivery	Uni: 16007 95 - 174 mm
Min height	Uni 95 - 174 mm + 50 mm height extension
Arm length min.-max.	636 - 1290 mm

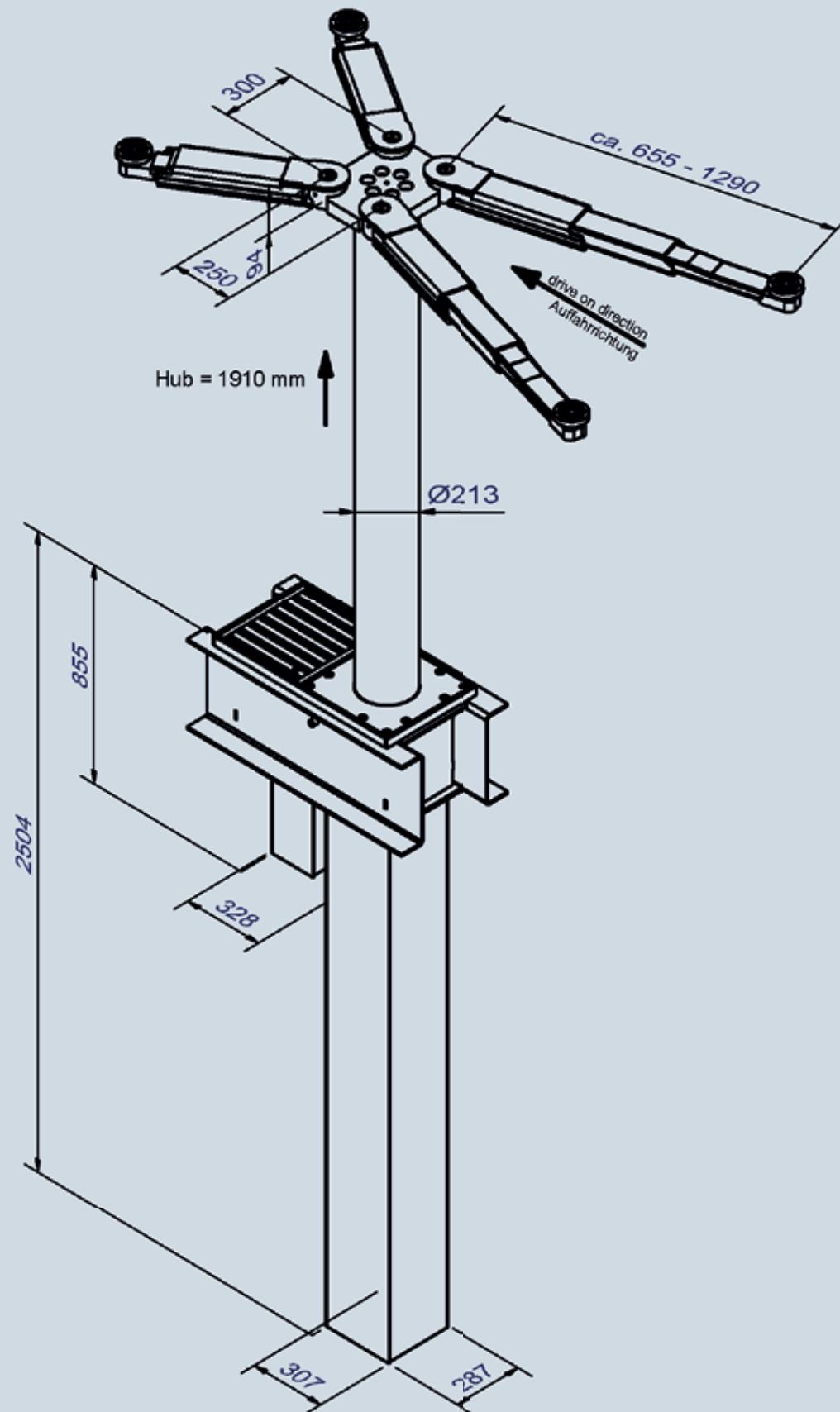

Illustrations and technical data are non-binding and may be subject to change. We reserve the right to make modifications and adjustments. Edition 12/2024



VAS 5246A Masterlift 2.35 NxT Pv 160-220 VW

ASE45504501000:

Electro-hydraulic twin-ram lift 3.5 t,
with repair platform



→ The perfect assistant for quick, safe and convenient work in the workshop!

The **VAS 5246A I Masterlift 2.35 NxT Pv 160-220 VW** is optimally suited for quick and easy vehicle lifting. Die The premium repair platforms are constructed of very strong and rigid solid steel that offers a high degree of stability. They are zinc-coated and painted. Looks great and works great!

The repair platforms, which come with xy-function in the premium version as standard, make **VAS 5246A I Masterlift 2.35 NxT Pv 160-220 VW** the perfect helper in your workshop.

The handy, non-slip and form-fitting rubber pads ensure that the vehicle is lifted with pinpoint accuracy. The strong 140 mm diameter cylinders are designed for long-lasting functionality and further round off the high-quality level, which ensures low maintenance requirements.

Even in the event of a power blackout, the lift can still be lowered without any problem thanks to the pneumatic emergency lowering system.

The **VAS 5246A I Masterlift 2.35 NxT Pv 160-220 VW** is perfectly completed by a control system that is both visually and technically convincing.

Standard colour:

Pv Premium: zinc coated and painted - RAL 9006

Options:

Rubber blocks in different heights

Installation variants:

On-floor installation

Ceiling installation

Optionally available:

Self-supporting installation, without load on the bottom of the sub-casing

Scope of delivery:

VAS 5246A I Masterlift 2.35 NxT Pv 160-220 VW
ASE45504501000

Order no.	Item no.	#	Part of the approval
20012129	14107	1	Repair platform 2.35 Pv 160-220 - solid steel, zinc-coated and painted RAL 9006, with aluminium mounting plates incl. xy plates
	14050	1	Hydraulic unit ML 2.35 NxT, Ø140 mm, PD 1550, stroke 1915 mm, with aluminium cover and 1 set of piston support floor plates
	12561	1	VW specification VAS 5246A
	11063	1	Set of cables 10 m
	12033	1	Ecological hydraulic fluid 10 ltr
	11104	1	Set of 2 magnetic tool trays
	11103	1	Document holder

Not included in the scope of approval, please order separately:

Frame: Standard: completely hot-dip galvanized

Sub-casing: Standard: painted
Optional: hot-dip galvanized or plastic-coated

VAS 5246A Masterlift

2.35 NxT Pv 160-220 VW

ASE45504501000

Technical data

Lifting capacity	3500 kg
Stroke length	1915 mm
Working height	1980 mm + Gummiauflagen
Cylinder diameter	2 x 140 mm
Distance between cylinders	1550 mm
Lifting/Lowering time	~ 30 sec.
Foundation depth	2640 mm
Pump unit	3.0 kW
Hydraulic oil	10 l
Voltage	230/400 V / 50 Hz / 16 A

Pv superstructure

Total length, min.-max.	160-220: 1600-2200 mm
Drive-over height	65 mm

When adapting to existing steel cassettes, the stroke/working height and piston distance may vary.

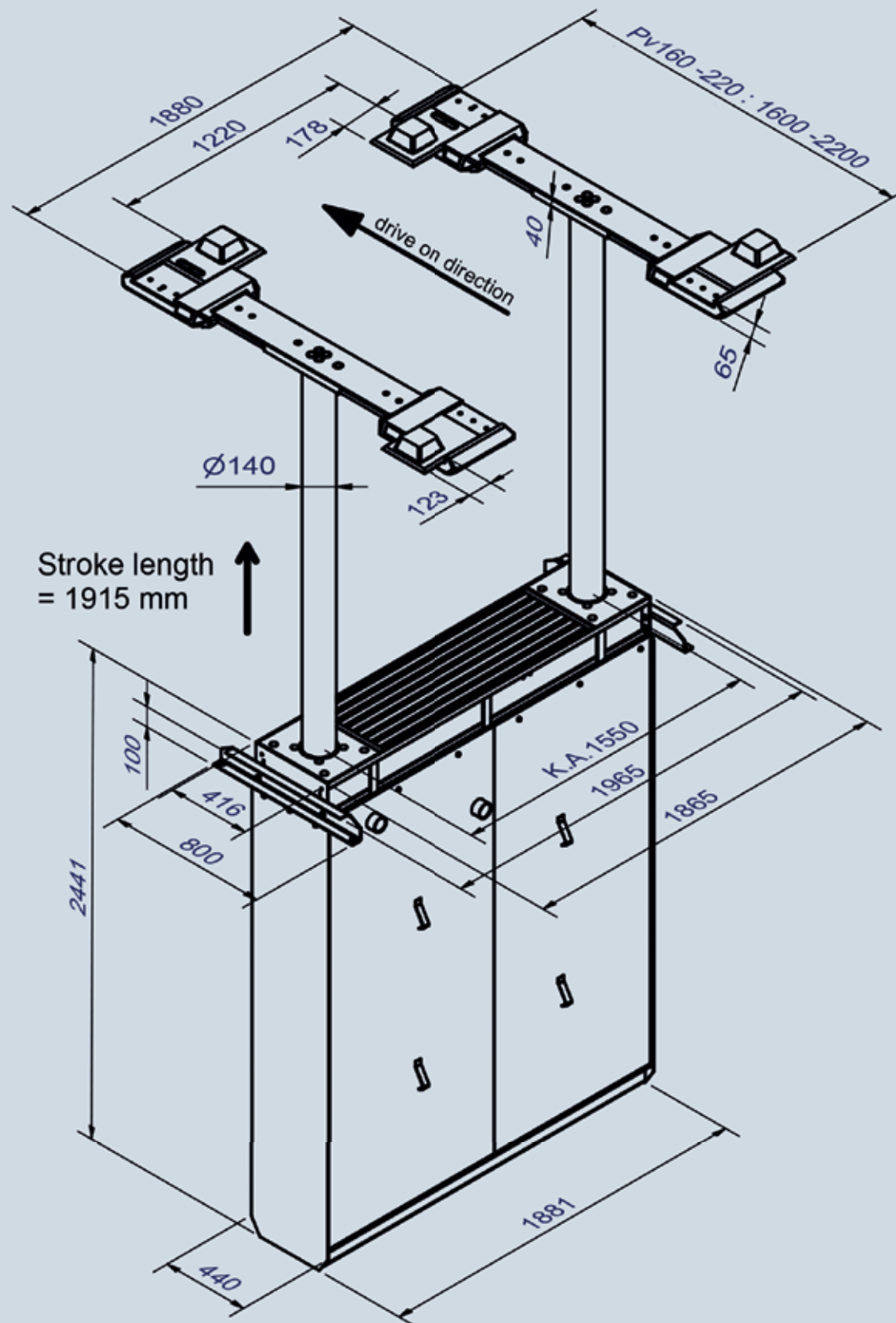

VAS-approved lifts, not only in new buildings but also for retrofitting in existing steel cassettes.

→ Adaption to existing cassettes on request

Valid for twin-ram lifts with a lifting capacity of up to 3.5 t.

Situation 1: The lift is at the end of its lifetime and needs to be replaced.

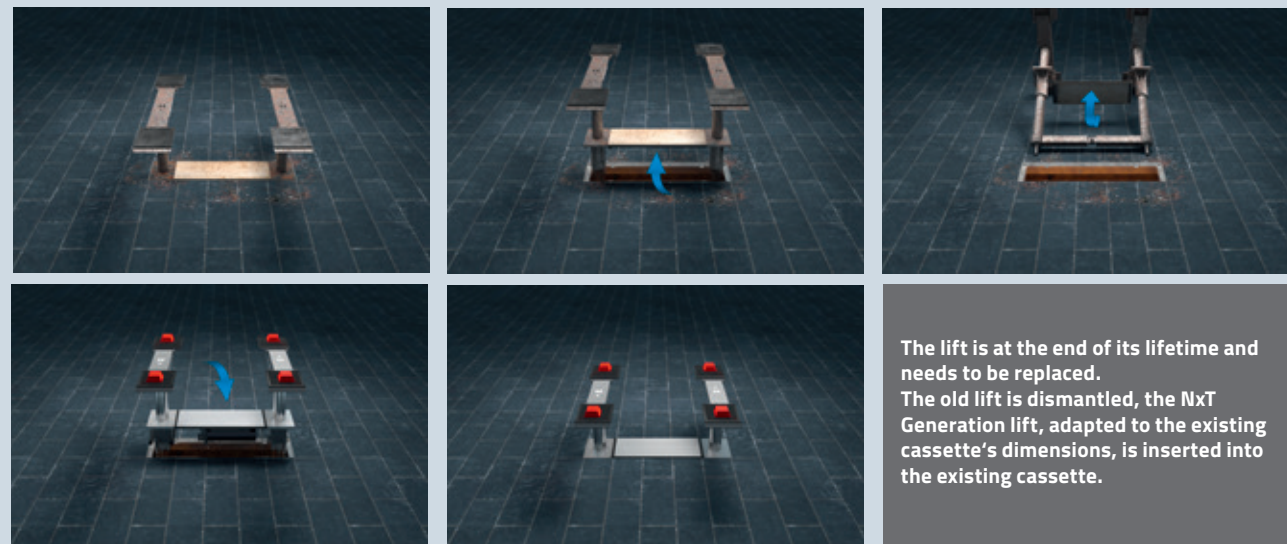

Situation 2: The top frame of the cassette does not have the right strength anymore.

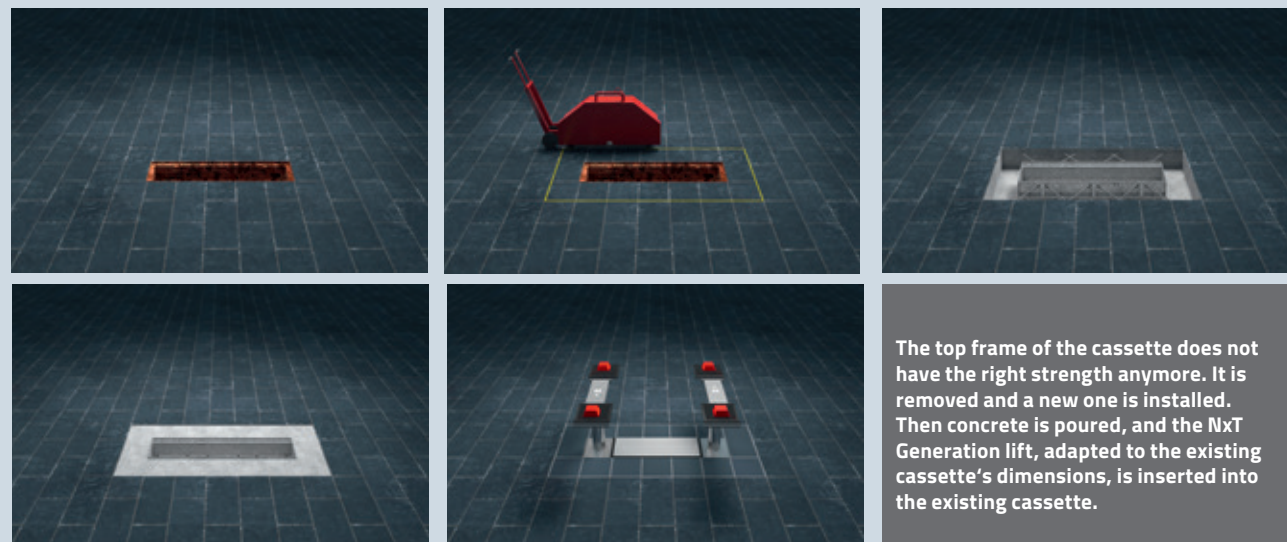

Situation 3: The customer would like to have a wider piston distance.

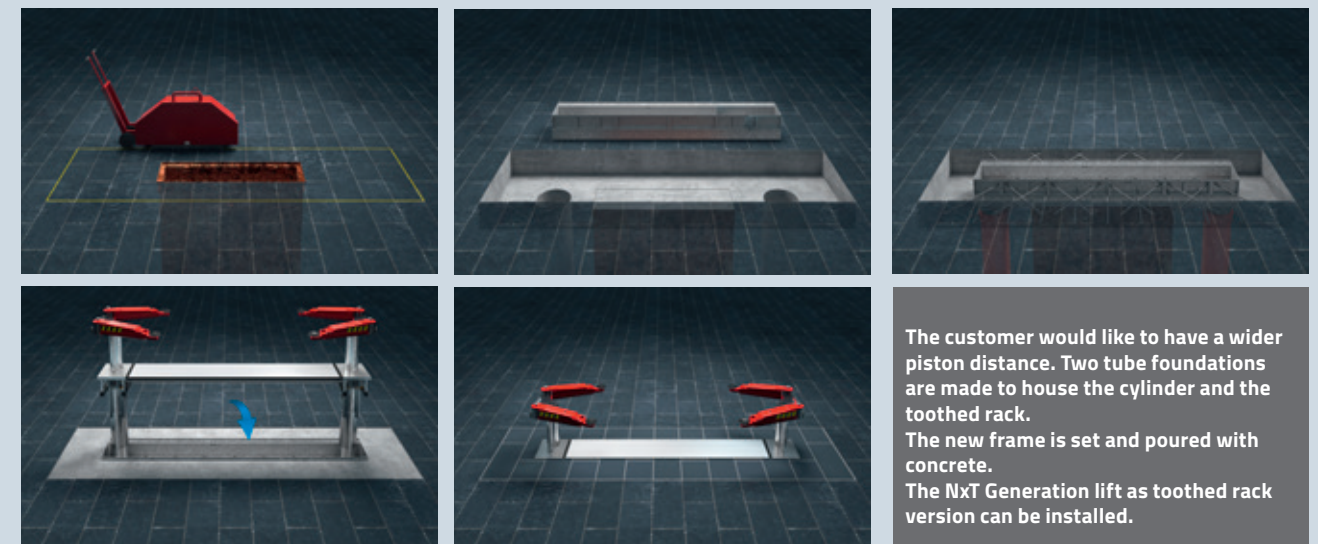

Too OLD? Get it NEW!



VAS 782 003A

Masterlift

2.35 NxT Saa 260 VW

ASE78200381000:

Electro-hydraulic twin-ram lift 3.5 t,
with swivel arm superstructure



Adaption to existing cassettes on request.

→ The smart lift for all types of vehicles
– safe, reliable and easy to use!

The double telescopic swivel arms convince with a very low minimum height, which even makes it possible to lift low-profile sports cars without any problems.

Tyres and rims are protected in the best possible way by the rounded design of the superstructure's chassis. The internal arm locking system installed as standard reliably protects against external influences.

The strong 140 mm diameter cylinders are designed for long-lasting functionality and further round off the high quality level, which ensures low maintenance requirements. Even in the event of a power blackout, the lift can still be lowered without any problem thanks to the pneumatic emergency lowering system.

The **VAS 782 003A I Masterlift 2.35 NxT Saa 260 VW** is perfectly completed by a control system that is both visually and technically convincing.

Standard colour:

Base plate: RAL 7012

Arms: RAL 7012

Options:

Wide range of extra pads, depending on vehicle type

Installation variants:

On-floor installation

Ceiling installation

Optionally available:

Self-supporting installation, without load on the bottom of the sub-casing

Scope of delivery:

VAS 782 003A I Masterlift 2.35 NxT Saa 260 VW
ASE78200381000

Order no.	Item no.	#	Part of the approval
20012130-1	21214	1	Swivel arm superstructure 2.35 Saa 260 Universal, double telescopic lifting pads 16007 Ø50mm, pick-up height min. 95 mm / max. 174 mm
	12562	1	VW specification VAS 782 003A
	11103	1	Document holder
	11104	1	Set of 2 magnetic tool trays
20012130-2	16010	4	Lifting pad extensions 50 mm - Ø50 mm 1 pc.
	14051	1	Hydraulic unit ML 2.35 NxT, Ø140 mm, PD 2600, stroke 1915 mm, with aluminium cover and 1 set of piston support floor plates
	11063	1	Set of cables 10 m
	12033	1	Ecological hydraulic fluid 10 ltr.

Not included in the scope of approval, please order separately:

Frame: Standard: completely hot-dip galvanized

Sub-casing: Standard: painted

Optional: hot-dip galvanized or plastic-coated

VAS 782 003A

Masterlift

2.35 NxT Saa

ASE78200381000

Technical data

Lifting capacity	3500 kg
Stroke length	1915 mm
Working height	Universal: 2010 - 2089 mm
Cylinder diameter	2 x 140 mm
Distance between cylinders	2600 mm
Lifting/Lowering time	~ 30 sec.
Foundation depth	2640 mm
Pump unit	3.0 kW
Hydraulic oil	10 l
Voltage	230/400 V / 50 Hz / 16 A

Arm superstructure

Total width	3000 mm
Lifting pad included in the delivery	Uni: 16007 95 - 174 mm
Drive-through width	2460 mm
Min. height	Uni 95 - 174 mm + 50 mm height extension
Arm length min.-max.	658 - 1313 mm
Insertion height in swivel arm	55 mm

When adapting to existing steel cassettes, the stroke/working height and piston distance may vary.

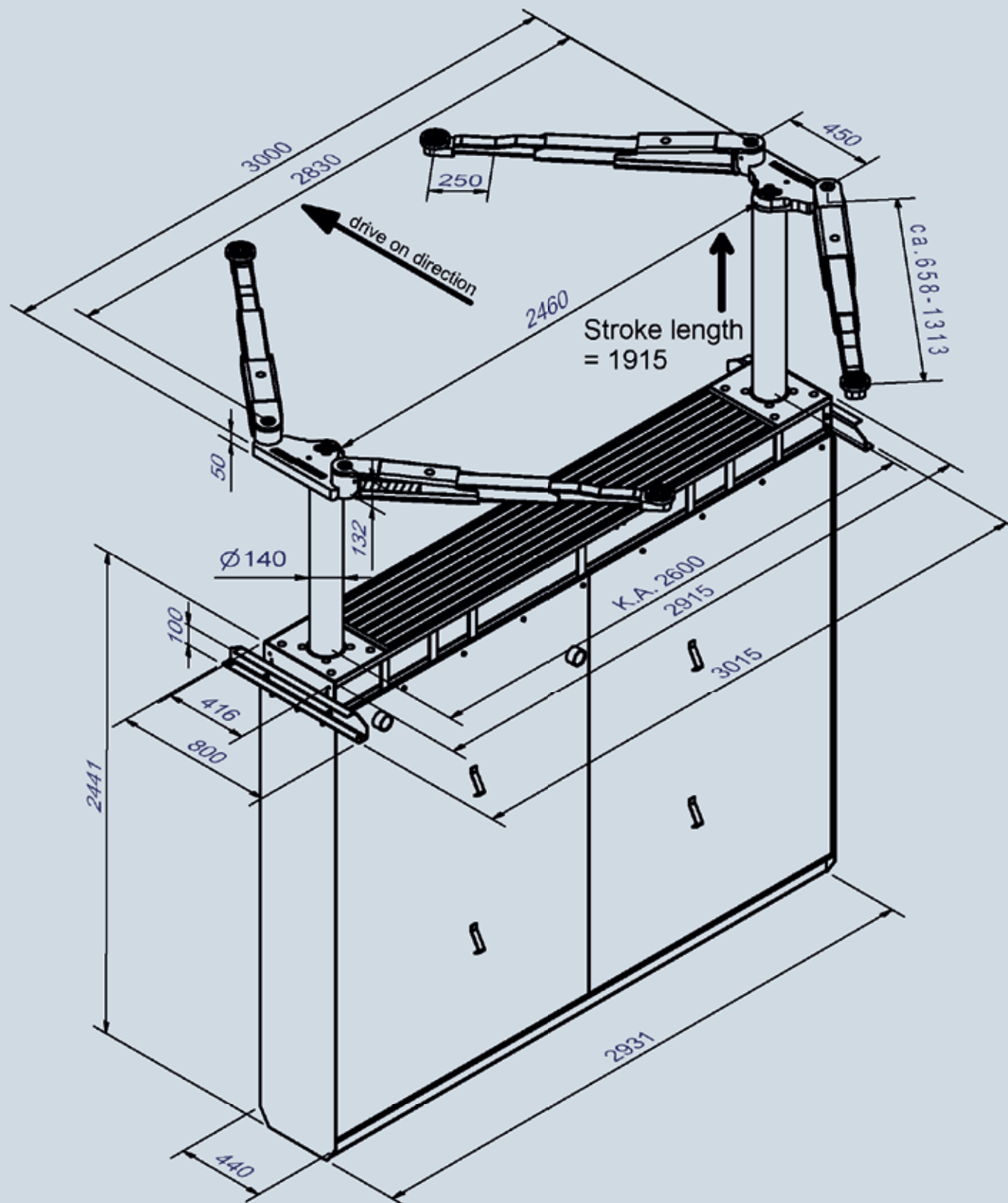

Illustrations and technical data are non-binding and may be subject to change. We reserve the right to make modifications and adjustments. Edition 12/2024



VAS-approved lifts, not only in new buildings but also for retrofitting in existing steel cassettes.

→ Adaption to existing cassettes on request

Valid for twin-ram lifts with a lifting capacity of up to 3.5 t.

Situation 1: The lift is at the end of its lifetime and needs to be replaced.

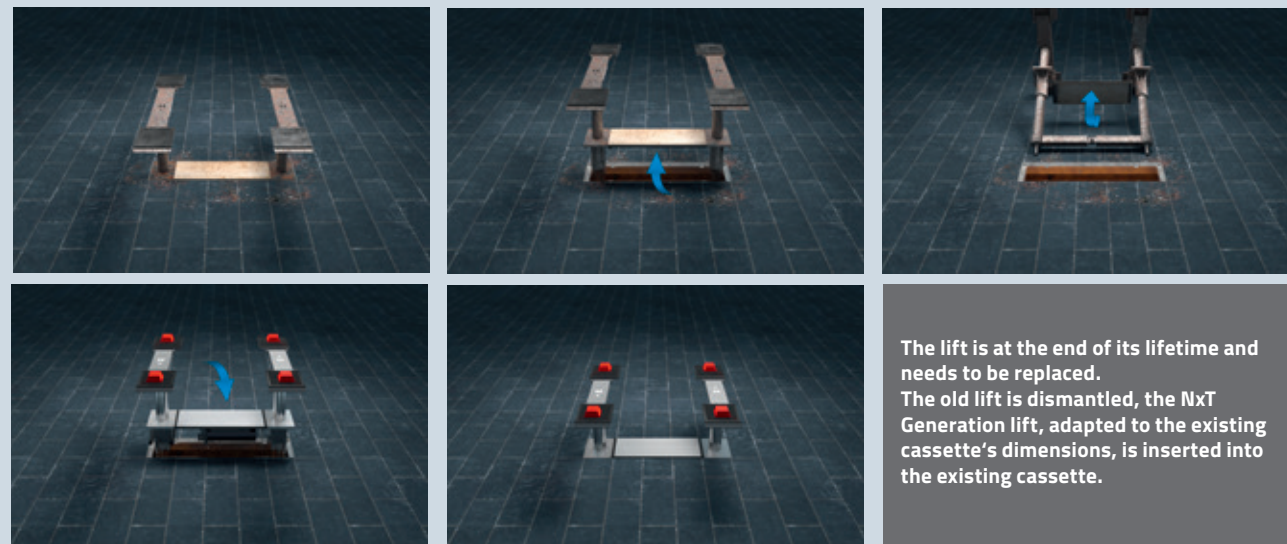

Situation 2: The top frame of the cassette does not have the right strength anymore.

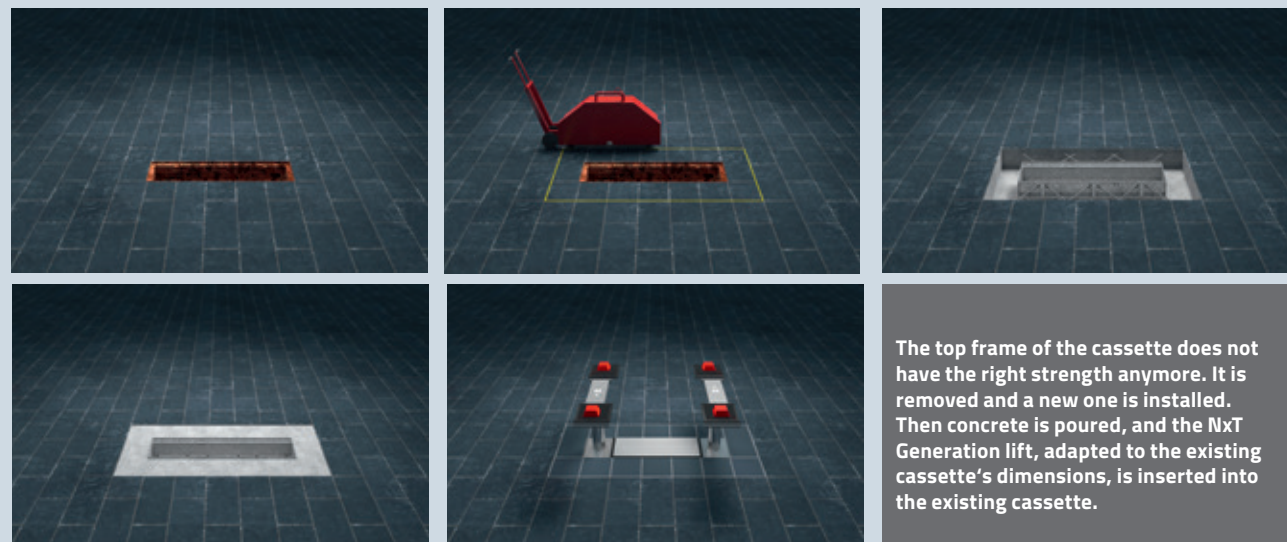

Situation 3: The customer would like to have a wider piston distance.

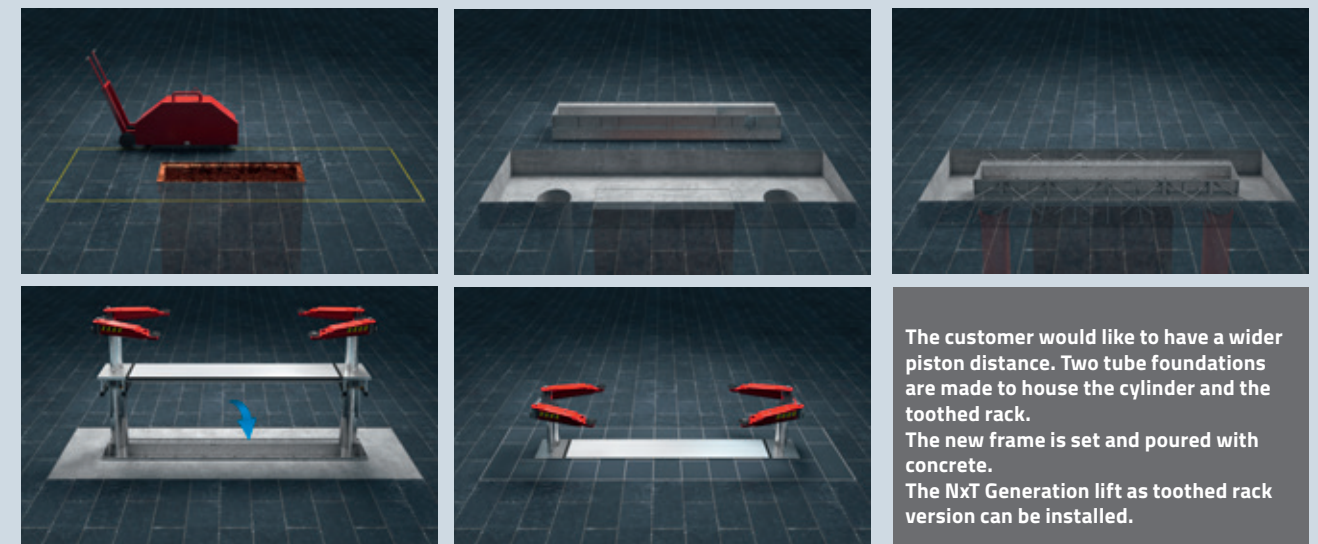

Too OLD? Get it NEW!



VAS 782 019A Masterlift 2.35 Combi Check-in KA 1550 VW

ASE78201981000:

Electro-hydraulic 2xtwin-ram lift 3.5 t,
with platforms and free-wheel lift with flat lifting supports

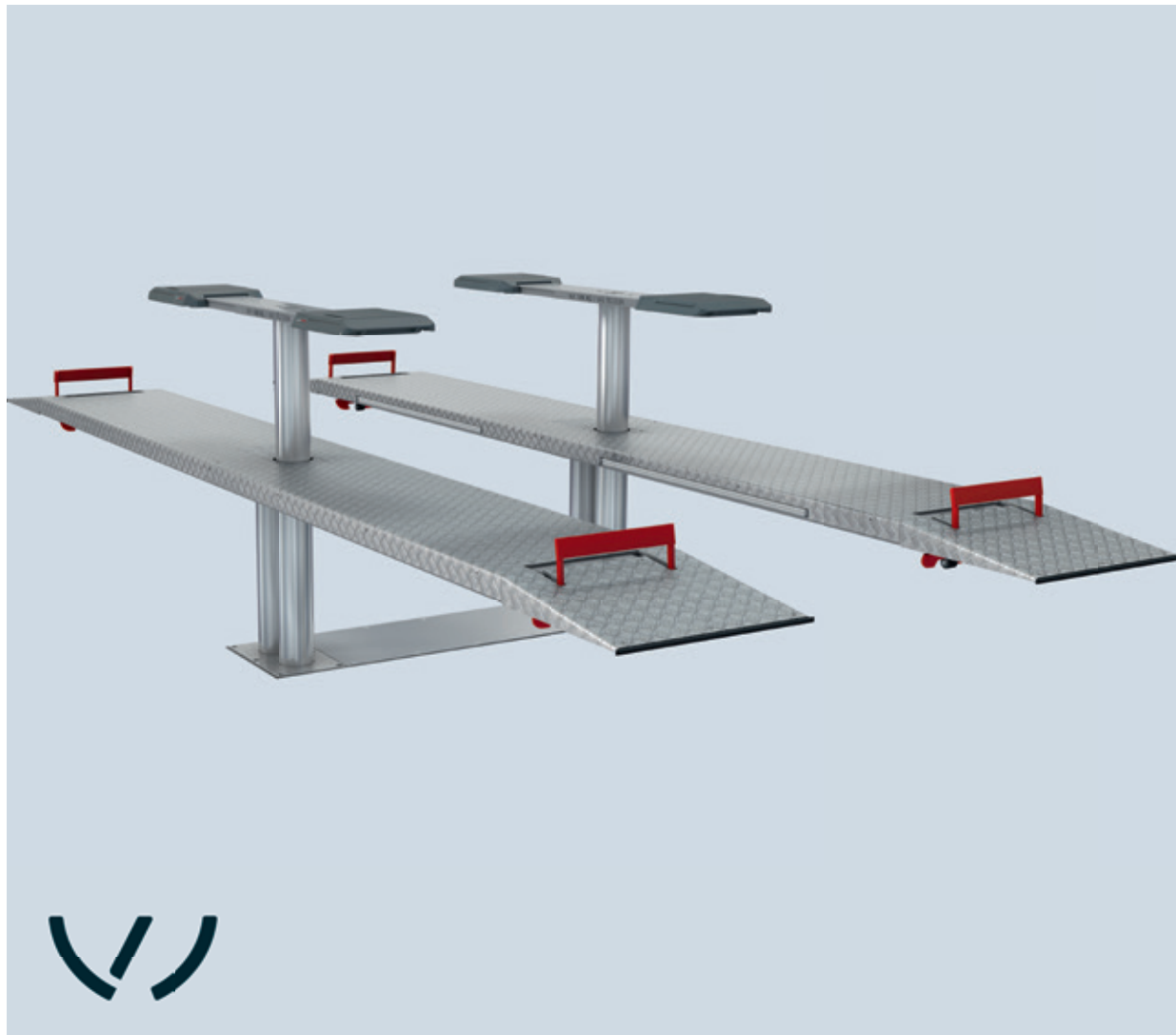

→ The all-rounder for quick and safe work in the garage!

The VAS 782 019A I Masterlift 2.35 Combi Check-in KA 1550 is optimally suited for quick and easy vehicle lifting.

The platforms are constructed of very strong and rigid solid steel that offers a high degree of stability. The repair platforms, which come with xy-function as standard, make the VAS 782 019A I Masterlift 2.35 Combi Check-in KA 1550 the perfect helper in your workshop.

4 strong 140 mm cylinders are designed for long-lasting functionality and further round off the high quality level which ensures low maintenance requirements. Even in the event of a power blackout the lift can still be lowered without any problems thanks to the pneumatic emergency lowering system.

The VAS 782 019A I Masterlift 2.35 Combi Check-in KA 1550 is perfectly completed by a control system that is both visually and technically convincing.

Standard colour:

Platforms: RAL 7012 and Aluminium coating with integrated LED-lighting

Pv Premium: zinc coated and painted

Options:

Set of rubber blocks 40, 60, 80 and 100 mm

Installation variants:

On-floor installation

Recessed-installation

Scope of delivery:

VAS 782 019A I Masterlift 2.35 Combi Check-in KA 1550 VW
ASE78201981000

Order no.	Item no.	#	Part of the approval
20012131-1	21500	1	Platform superstructure 2.35 F 440 Combi Check-in, on-floor, with ramps and integrated automatically rising stoppers in front and rear, incl. LED lighting
	12563	1	VW specifications VAS 782 019A
	11103	1	Document holder
	11104	1	Set of 2 magnetic tool trays
	21080	1	Power distribution for 1 platform (Schuko plug 230 V / 16 A / IP54)
20012131-2	21096	1	Pneumatic installation for 1 platform (1 T-piece each front and back)
	10290	1	Hydraulic unit ML 2.35 Combi Check-in, PD 1550, stroke 1900 mm
	21504	1	Repair platform superstructure 2.35 Pv 160 - 220 xy, solid steel, zinc coated and hammer painted, RAL 9006, for Combi Lift
	11071	1	Set of cables JE 10 m
	12036	1	Ecological hydraulic fluid 17 ltr
	11102	1	Pyramid shape rubber blocks h = 40 mm, bottom 120x120 mm, top Ø100 mm, 1 set = 4 pieces

Not included in the scope of approval, please order separately:

Steel cassette:

Standard: painted

Optional: hot-dip galvanized or plastic-coated

VAS 782 019A

Masterlift

2.35 Combi Check-in

KA1550 VW

ASE78201981000

Technical data

Lifting capacity	3500 kg
Stroke length	1870 mm
Working height	F: 1965 mm RFH: 2030 mm + rubber pads
Cylinder diameter	4 x 140 mm
Distance between cylinders	1550 mm
Lifting/Lowering time	~ 30 sec.
Foundation depth	2625 mm
Pump unit	3.0 kW
Hydraulic oil	14 l
Voltage	230/400 V / 50 Hz / 16 A

Pv superstructure

Total length, min.- max.	160-220: 1600-2200 mm
Min. height	65 mm

Platforms

Total length	5580 mm
Platform width - Measurements depend on platform length	650 mm
Usable length of platform	4400 mm
Wheel base, min.-max.	3900 mm
Distance between platforms	900 mm
Drive-on height	95 mm

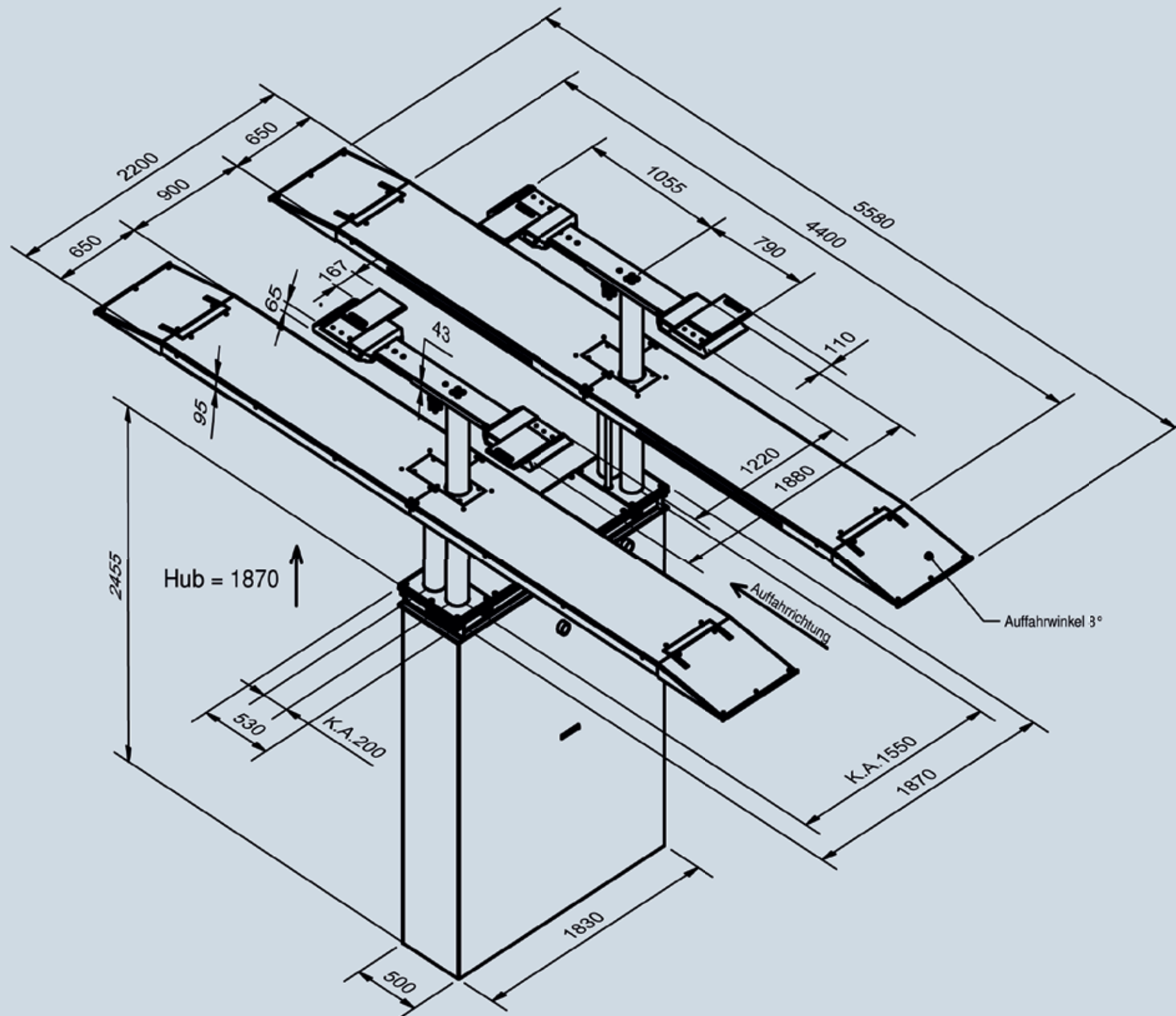

Illustrations and technical data are non-binding and may be subject to change. We reserve the right to make modifications and adjustments. Edition 12/2024

VAS 782 035A Biglift 2.55 Saa 230 VW

ASE78203581000:

Electro-hydraulic twin-ram lift 5.5 t,
with swivel arm superstructure



→ The ideal lift for large cars and commercial vehicles – flexible, safe and low-maintenance!

The double telescopic swivel arms convince with an unconventional lifting area, especially suited for utility vehicles and large passenger cars.
The internal arm locking system installed as standard reliably protects against external influences.
The strong 213 mm diameter cylinders are also designed for long-lasting functionality and further round off the high quality level which ensures low maintenance requirements.
Even in the event of a power blackout the lift can still be lowered without any problems thanks to the pneumatic emergency lowering system.
The **VAS 782 035A | Biglift 2.55 Saa 230 VW** is perfectly completed by a control system that is both visually and technically convincing.

Standard colour:

RAL 7012

Options:

Wide range of extra pads, depending on vehicle type

Installation variants:

Superstructure on floor

Ceiling installation

Scope of delivery:

VAS 782 035A | Biglift 2.55 Saa 230 VW
ASE78203581000

Order no.	Item no.	#	Part of the approval:
20012132-1	21202	1	Superstructure 2.55 Saa 230 Ø 213, incl. lifting pad 11028 (135 -195 mm), Ø 50 mm
	12564	1	VW specification VAS 782035A
	11103	1	Document holder
	11104	1	Set of 2 magnetic tool trays
20012132-2	16010	4	Lifting pad extension 50 mm - Ø50 mm 1 pc.
	11063	1	Set of cables 10 m
	10308	1	Hydraulic unit BL PD 2150 mm, stroke 1860 mm, cylinder Ø 213 mm
	12036	1	Ecological hydraulic fluid 17 ltr.

Not included in the scope of approval, please order separately:

Steel cassette:

Standard: painted

Optional: hot-dip galvanized or plastic-coated

VAS 782 035A

Biglift

2.55 Saa 230 VW

ASE78203581000

Technical data

Lifting capacity	5500 kg
Stroke length	1865 mm
Working height	1963 - 2010 mm
Cylinder diameter	2 x 213 mm
Distance between cylinders	2150 mm
Lifting/Lowering time	~ 45 sec.
Foundation depth	2625 mm
Pump unit	3.0 kW
Hydraulic oil	17 l
Voltage	230/400 V / 50 Hz / 16 A

Arm superstructure

Total width	3500 mm
Lifting pad included in the delivery	16008: 98 - 145 mm
Drive-through width	1930 mm
Min. height	98 - 145 mm
Arm length min.-max.	852 - 1725 mm
Insertion height in swivel arm	55 mm

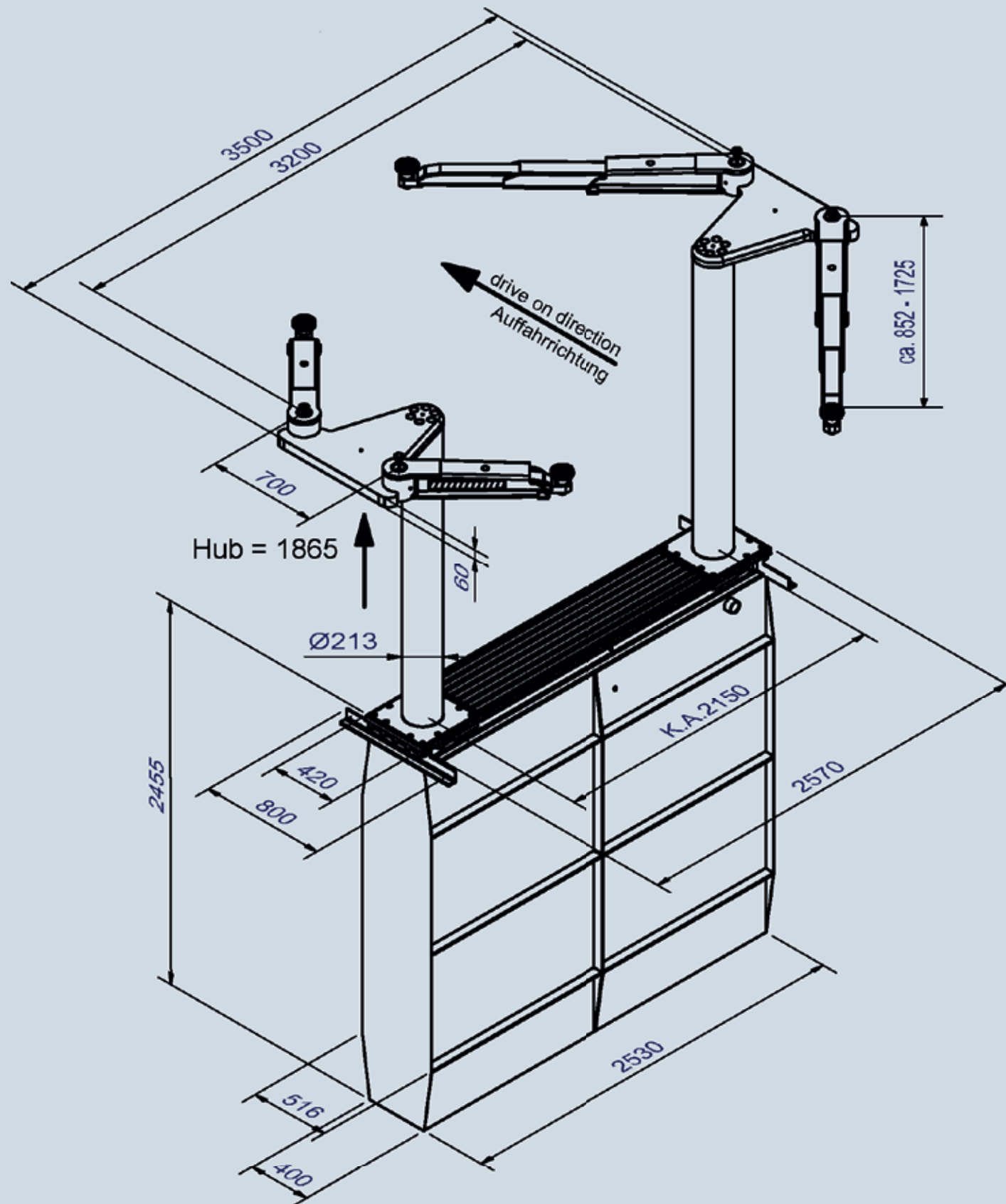

Illustrations and technical data are non-binding and may be subject to change. We reserve the right to make modifications and adjustments. Edition 12/2024



VAS 782 037A

Biglift 2.55 Saa 265 VW

ASE78203781000:

Electro-hydraulic twin-ram lift 5.5 t,
with swivel arm superstructure



→ The ideal lift for large cars and commercial vehicles – flexible, safe and low-maintenance!

The double telescopic swivel arms convince with an unconventional lifting area, especially suited for utility vehicles and large passenger cars.

The internal arm locking system installed as standard reliably protects against external influences.

An integrated mechanical safety ratchet offers additional safety for all working procedures.

The strong 213 mm diameter cylinders are also designed for long-lasting functionality and further round off high quality level which ensures low maintenance requirements.

Even in the event of a power blackout the lift can still be lowered without any problems thanks to the pneumatic emergency lowering system.

The **VAS 782 037A | Biglift 2.55 Saa 265 VW** is perfectly completed by a control system that is both visually and technically convincing.

Standard colour:

RAL 7012

Options:

Wide range of extra pads, depending on vehicle type

Installation variants:

Superstructure on floor

Ceiling installation

Scope of delivery:

VAS 782 037A | Biglift 2.55 Saa 265 VW

ASE78203781000

Oder no.	Item no.	#	Part of the approval:
20012133-1	21203	1	Superstructure 2.55 Saa 265 Ø213, incl. 4 single telescopic lifting pads 16008, Ø 50mm
	12565	1	VW specification VAS 782037A
	11103	1	Document holder
	11104	1	Set of 2 magnetic tool trays
20012133-2	16010	4	Lifting pad extension 50 mm – Ø50 mm 1 pc.
	11063	1	Set of cables 10 m
	10309	1	Hydraulic unit BL PD 2650 mm, stroke 1860 mm, cyl. Ø 213 mm
	12036	1	Ecological hydraulic fluid 17 ltr.

Not included in the scope of approval, please order separately:

Steel cassette:

Standard: painted

Optional: hot-dip galvanized or plastic-coated

VAS 782 037A

Biglift

2.55 Saa 265 VW

ASE78203781000

Technical data

Lifting capacity	5500 kg
Stroke length	1860 mm
Working height	1963 - 2010 mm
Cylinder diameter	2 x 213 mm
Distance between cylinders	2650 mm
Lifting/Lowering time	~ 45 sec.
Foundation depth	2625 mm
Pump unit	3.0 kW
Hydraulic oil	17 l
Voltage	230/400 V / 50 Hz / 16 A

Arm superstructure

Total width	3500 mm
Lifting pad included in the delivery	16008: 98 - 145 mm
Drive-through width	2430 mm
Min. height	98 - 145 mm
Arm length min.-max.	852 - 1725 mm
Insertion height in swivel arm	55 mm

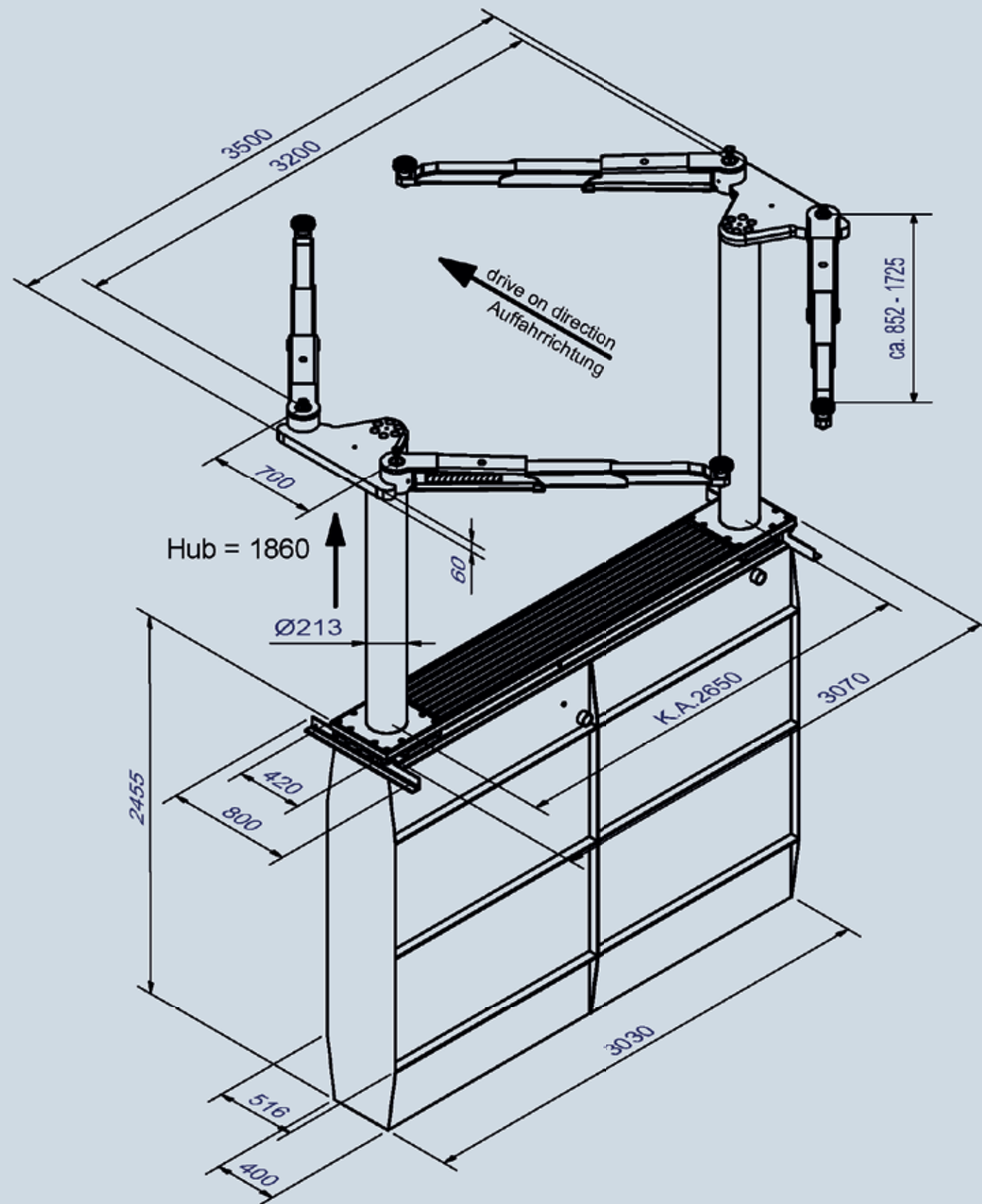

Illustrations and technical data are non-binding and may be subject to change. We reserve the right to make modifications and adjustments. Edition 12/2024



VAS 782 027A Biglift 4.55 Combi VW

ASE78202781000:

Electro-hydraulic 2x4-ram lift 5.5 t,
platforms and free-wheel lift with arms



→ The all-round, reliable workshop assistant for quick vehicle reception!

The **VAS 782 027A | Biglift 4.55 Combi VW** is optimally suited for quick and easy vehicle lifting. The platforms are constructed of very strong and rigid solid steel that offers a high degree of stability. The additional swivel arms, which come with double telescopic and crosswise adjustable swivel arms as standard, make the **VAS 782 027A | Biglift 4.55 Combi VW** the perfect helper in your workshop. 2x4 strong mm diameter cylinders are also designed for long-lasting functionality and further round off the high quality level which ensures low maintenance requirements. Even in the event of a power blackout the lift can still be lowered without any problems thanks to the pneumatic emergency lowering system. The **VAS 782 027A | Biglift 4.55 Combi VW** is perfectly completed by a control system that is both visually and technically convincing.

Standard colour:

RAL 7012

Options:

Wide range of extra pads, depending on vehicle type

Installation variants:

Superstructure on floor

Superstructure in floor with or without flush-floor device

Scope of delivery:

VAS 782 027A | Biglift 4.55 Combi VW
ASE78202781000

Order no.	Item no	#	Part of the approval:
20012134-1	21509	1	Platform superstructure 4.55 Fn 550 Combi
	21205	1	Swivel arm superstructure 4.55 Saav 155 Combi, incl. lifting pads 11028, minimum height 135 mm, Ø 50 mm, with Ø 50 - 40 mm reducers
	12566	1	VW specification VAS 782027A
	16010	4	Pad extensions 50 mm - Ø50 mm 1 pc
	21100	1	Drive-on ramp on floor 1100 mm 10°, 1 set = 2 pcs.
	21084	1	Roll-off safety device, H = 100 mm, 1 set = 2 pcs.
	12942	1	LED lighting for vehicle bottom, 3 pcs. per platform
	11103	1	Document holder
	11104	1	Set of 2 magnetic tool trays
	21080	1	Power distribution for 1 platform (Schuko plug 230 V / 16 A / IP54)
21096	1	Pneumatic installation for 1 platform (1 T-piece each front and back)	
20012134-2	10295	1	Hydraulic unit BL 4.55-1240/1850-Combi on floor or in floor without flush floor device
	11071	1	Set of cables JE 10 m
	12038	1	Ecological hydraulic fluid 20 ltr.

Not included in the scope of approval, please order separately:

Steel cassette: Standard: painted | Optional: hot-dip galvanized or plastic-coated

VAS 782 027A

Biglift 4.55

Combi VW

ASE78202781000

Technical data

Lifting capacity	5500 kg
Stroke length	1895 mm
Working height	F: 2060 mm RFH: 2128 - 2175 mm
Cylinder diameter	8 x 140 mm
Distance between cylinders	1240/1850 mm
Lifting/Lowering time	~ 38 sec.
Foundation depth	2625 mm
Pump unit	3.0 kW
Hydraulic oil	20 l
Voltage	230/400 V / 50 Hz / 16 A

Arm superstructure

Total width	3134 mm
Lifting pad included in the delivery	16008 : 98 - 145 mm
Min. height	98 - 145 mm
Arm length min.-max.	725 - 1410 mm

Platforms

Total length	~ 6800 mm
Platform width - Measurements depend on platform length	650 mm
Usable length of platform	5500 mm
Wheel base, min.-max.	~ 5000 mm
Distance between platforms	900 mm
Drive-on height	165 mm

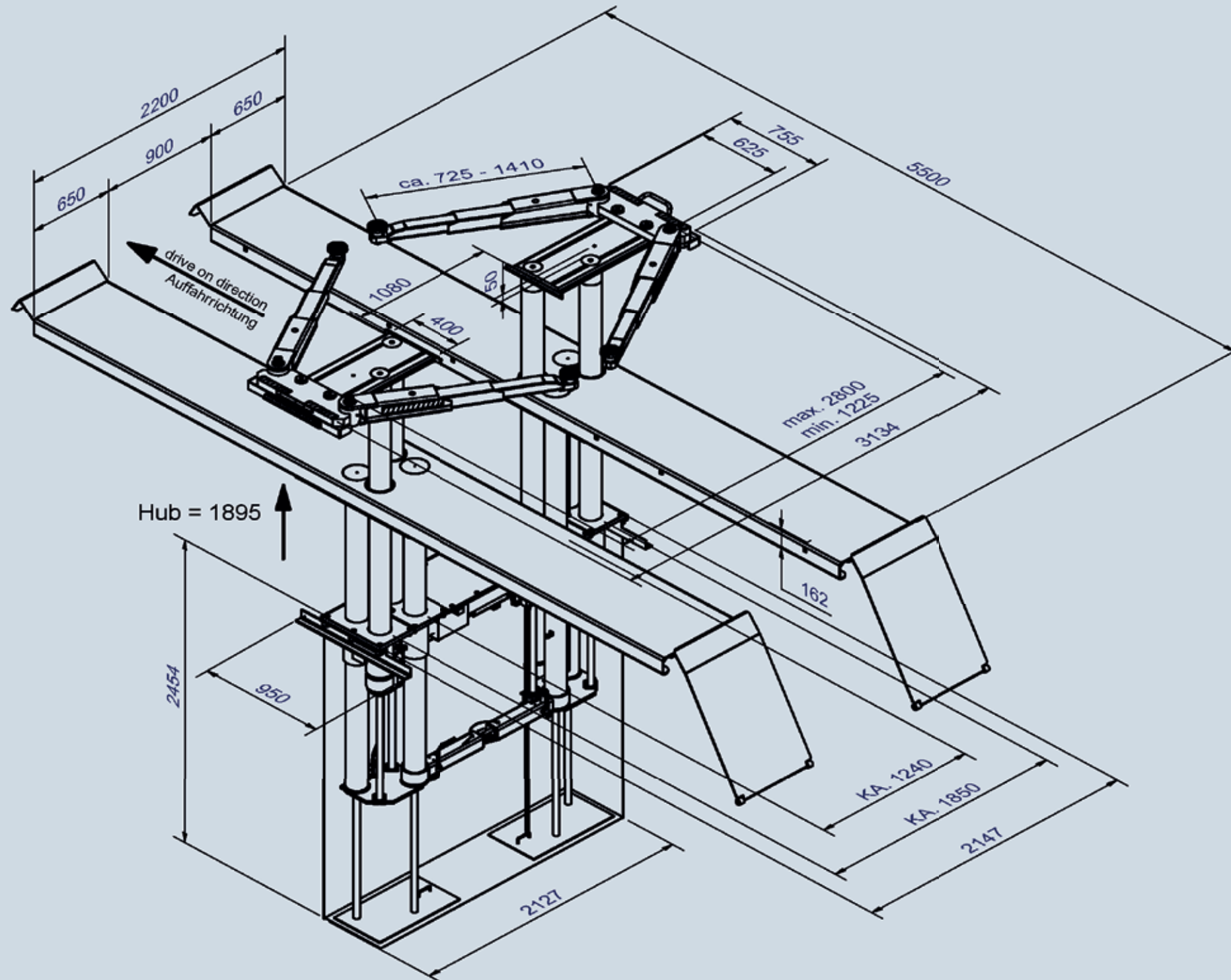

Illustrations and technical data are non-binding and may be subject to change. We reserve the right to make modifications and adjustments. Edition 12/2024

VAS 782 049

Biglift 2.65 Saaa 230 VW

ASE78204980000

Electro-hydraulic twin-ram lift 6.5 t,
with swivel arm superstructure

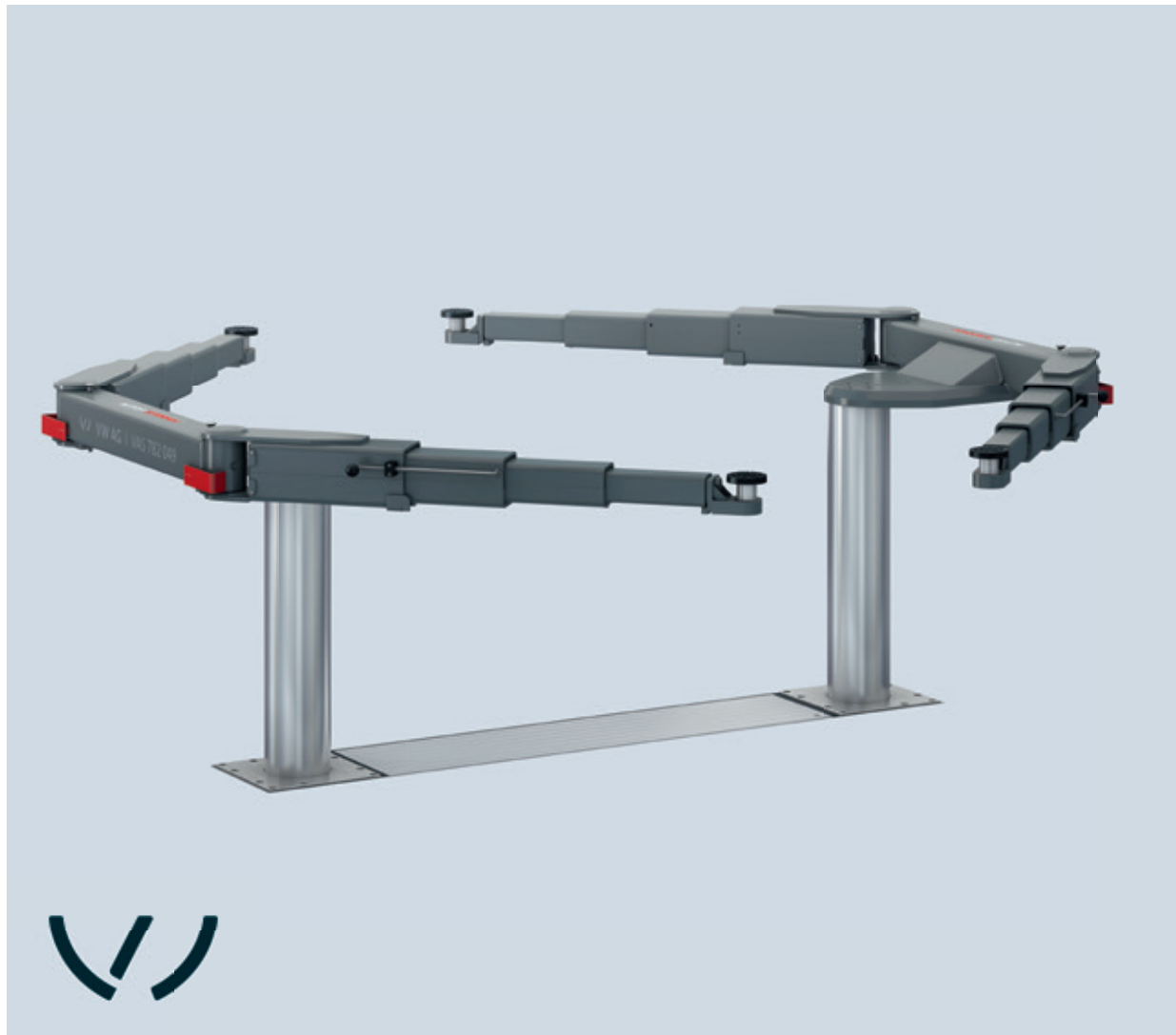

→ The flexible and safe lift for large vehicles and commercial vehicles!

The triple telescopic swivel arms convince with an unconventional lifting area, especially suited for utility vehicles and large passenger cars. The internal arm locking system installed as standard reliably protects against external influences. The strong 213 mm diameter cylinders are also designed for long-lasting functionality and further round off high quality level which ensures low maintenance requirements. Even in the event of a power blackout the lift can still be lowered without any problems thanks to the pneumatic emergency lowering system. The **VAS 782 049 I Biglift 2.65 Saaa 230 VW** is perfectly completed by a control system that is both visually and technically convincing.

Standard colour:

RAL 7012

Options:

Wide range of extra pads, depending on vehicle type

Installation variants:

Superstructure on-floor

Ceiling installation

Scope of delivery:

VAS 782 049 I Biglift 2.65 Saaa 230 VW
ASE78204980000

Oder no.	Item no.	#	Part of the approval
20012135-1	21209	1	Swivel arm superstructure 2.65 Saaa 230, incl. 4 single telescopic lifting pads 16008, Ø50 mm
	12567	1	VW specification VAS 782049
	11103	1	Document holder
	11104	1	Set of 2 magnetic tool trays
	16010	4	Lifting pad extension 50 mm - Ø50 mm 1 pc.
20012135-2	10276	1	Hydraulic unit BL Sa 6,5 t, PD 2150, stroke 1860 mm
	11063	1	Set of cables 10 m
	12036	1	Ecological hydraulic fluid 17 ltr.

Not included in the scope of approval, please order separately:

Steel cassette:

Standard: painted

Optional: hot-dip galvanized or plastic-coated

VAS 782 049

Biglift 2.65

Saaa 230 VW

ASE78204980000

Technical data

Lifting capacity	6500 kg
Stroke length	1865 mm
Working height	1963 - 2010 mm
Cylinder diameter	2 x 213 mm
Distance between cylinders	2150 mm
Lifting/Lowering time	~ 45 sec.
Foundation depth	2625 mm
Pump unit	3.0 kW
Hydraulic oil	17 l
Voltage	230/400 V / 50 Hz / 16 A

Arm superstructure

Total width	3350 mm
Lifting pad included in the delivery	16008: 98 - 145 mm
Drive-through width	1930 mm
Min. height	98 - 145 mm
Arm length min.-max.	790 - 1640 mm

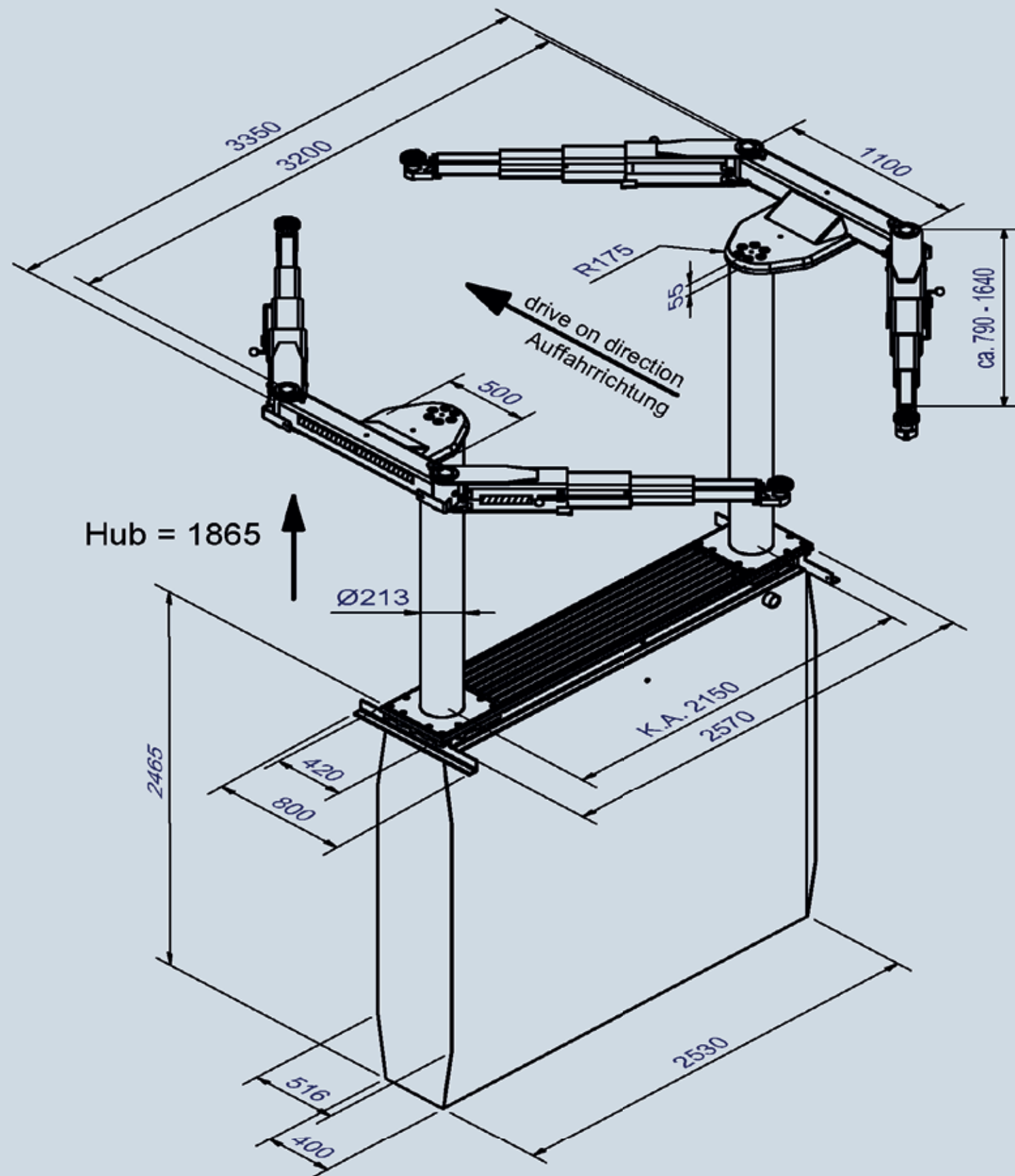

Illustrations and technical data are non-binding and may be subject to change. We reserve the right to make modifications and adjustments. Edition 12/2024



VAS 782 015A

Biglift 2.65 Saaa 265 VW

ASE78201581000

Electro-hydraulic twin-ram lift 6.5 t,
with swivel arm superstructure

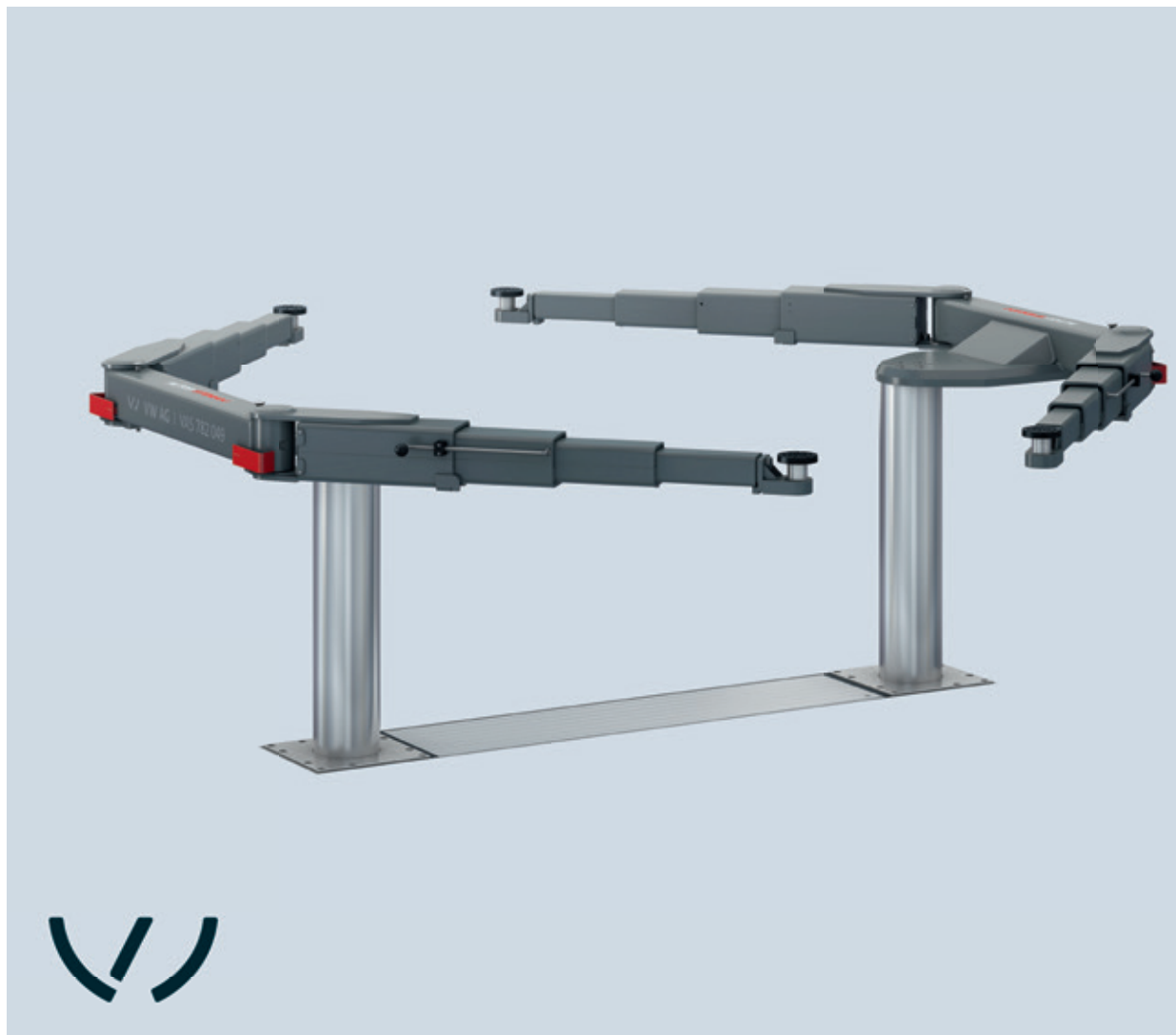

→ The flexible and safe lift for large vehicles and commercial vehicles!

The triple telescopic swivel arms convince with an unconventional lifting area, especially suited for utility vehicles and large passenger cars. The internal arm locking system installed as standard reliably protects against external influences. An integrated mechanical safety ratchet offers additional safety for all working procedures. The strong 213 mm diameter cylinders are also designed for long-lasting functionality and further round off the high quality level which ensures low maintenance requirements. Even in the event of a power blackout the lift can still be lowered without any problems thanks to the pneumatic emergency lowering system. The **VAS 782 015A | Biglift 2.65 Saaa 265 VW** is perfectly completed by a control system that is both visually and technically convincing.

Standard colour:

RAL 7012

Options:

Wide range of extra pads, depending on vehicle type

Installation variants:

Superstructure on-floor

Ceiling installation

Scope of delivery:

VAS 782 015A | Biglift 2.65 Saaa 265 VW

ASE78201581000

Order no.	Item no.	#	Part of the approval:
20012136-1	21210	1	Swivel arm superstructure 2.65 Saaa 265, incl. 4 single telescopic lifting pads 16008, Ø50 mm
	125687	1	VW specification VAS 782015A
	11103	1	Document holder
	11104	1	Set of 2 magnetic tool trays
	16010	4	Lifting pad extension 50 mm - Ø50 mm 1 pc.
20012136-2	10287	1	Hydraulic unit BL Sa 6,5 t 2650 mm
	11063	1	Set of cables 10 m
	12036	1	Ecological hydraulic fluid 17 ltr.

Not included in the scope of approval, please order separately:

Steel cassette:

Standard: painted

Optional: hot-dip galvanized or plastic-coated

VAS 782 015A

Biglift 2.65

Saaa 265 VW

ASE78201581000

Technical data

Lifting capacity	6500 kg
Stroke length	1865 mm
Working height	1963 - 2010 mm
Cylinder diameter	2 x 213 mm
Distance between cylinders	2650 mm
Lifting/Lowering time	~ 45 sec.
Foundation depth	2625 mm
Pump unit	3.0 kW
Hydraulic oil	17 l
Voltage	230/400 V / 50 Hz / 16 A

Arm superstructure

Total width	3350 mm
Lifting pad included in the delivery	16008: 98 - 145 mm
Drive-through width	2430 mm
Min. height	98 - 145 mm
Arm length min.-max.	790 - 1640 mm

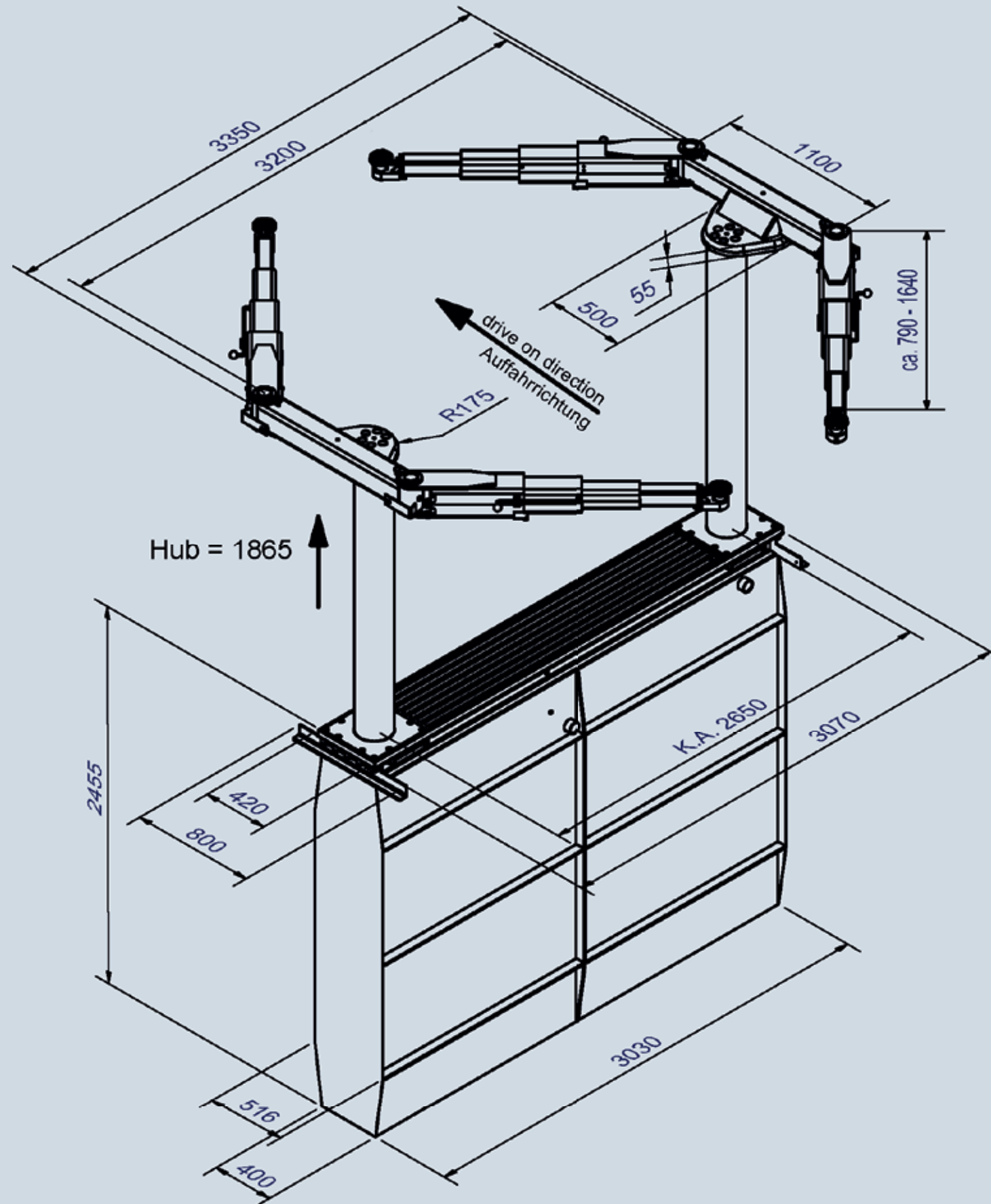

Illustrations and technical data are non-binding and may be subject to change. We reserve the right to make modifications and adjustments. Edition 12/2024



VAS 771 039A Maestro 35 F VW

ASE77103981000

Electro-mechanical 2-post lift 3.5 t



→ 2-post lift platform for maximum stability and an optimal door opening angle!

The 2-post lifts of the Maestro 35 series impress with their premium construction.

They come with extremely stable and welded columns.

Smooth running behaviour is ensured by the roller-bearing carriage.

The cold-rolled spindle guarantees a particularly long service life.

The columns are asymmetrically positioned, i. e. vehicles can be positioned far to the rear, which ensures an optimal door opening angle.

Of course, **VAS 771 039A | Maestro 35 F VW** also has a door stop protection to prevent damage during entry and exit.

The swivel arms are extremely flat and thus ensure a low minimum height. The internal arm locking system with strong 360° interlocking protects against moisture and dirt.

Standard colour:

Arms: RAL 7040

Posts: RAL 7012

Options:

Available with different portal heights

LED lighting set

Energy set with compressed air and socket-outlet

Extra control unit for second column

Large program of extra pads, depending on type of vehicle

Variants:

Available for different voltages

F = flex pad

Scope of delivery:

VAS 771 039A | Maestro 35 F VW

ASE77103981000

Order no..	Item no.	#	Part of the approval
20012137	089501	1	Maestro 35 F - DT/ST, 400/3/50 - 4350/5050 mm - Ø40
	776526	1	Portal set for Maestro 2.30/2.32/2.35/30/32/35, 4350 mm

VAS 771 039A

Maestro

35 F VW

ASE77103981000

Technical data

Lifting capacity	3500 kg
Stroke length	1900 mm
Working height	1995 - 2025 mm
Lifting/Lowering time	~ 40 sec.
Motor	2 x 2,8 kW
Voltage	3x400V-50Hz-25A

Arm superstructure

Total height post	2706 mm
Total height incl. portal	4350 mm
Drive-through width	2290 mm
Min. height	95 mm
Width between posts	2565 mm
Total width outer edges base plates	3320 mm
Total width outer edges posts	3075 mm
Arm length front, min.-max.	F DT: 600 - 1220 mm
Arm length rear, min.-max.	F ST: 900 - 1425 mm

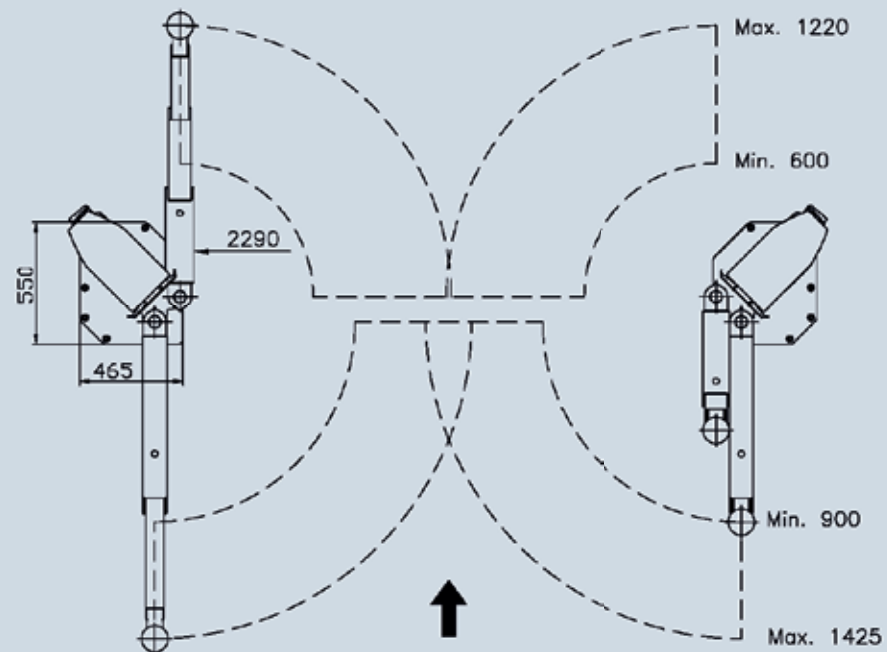
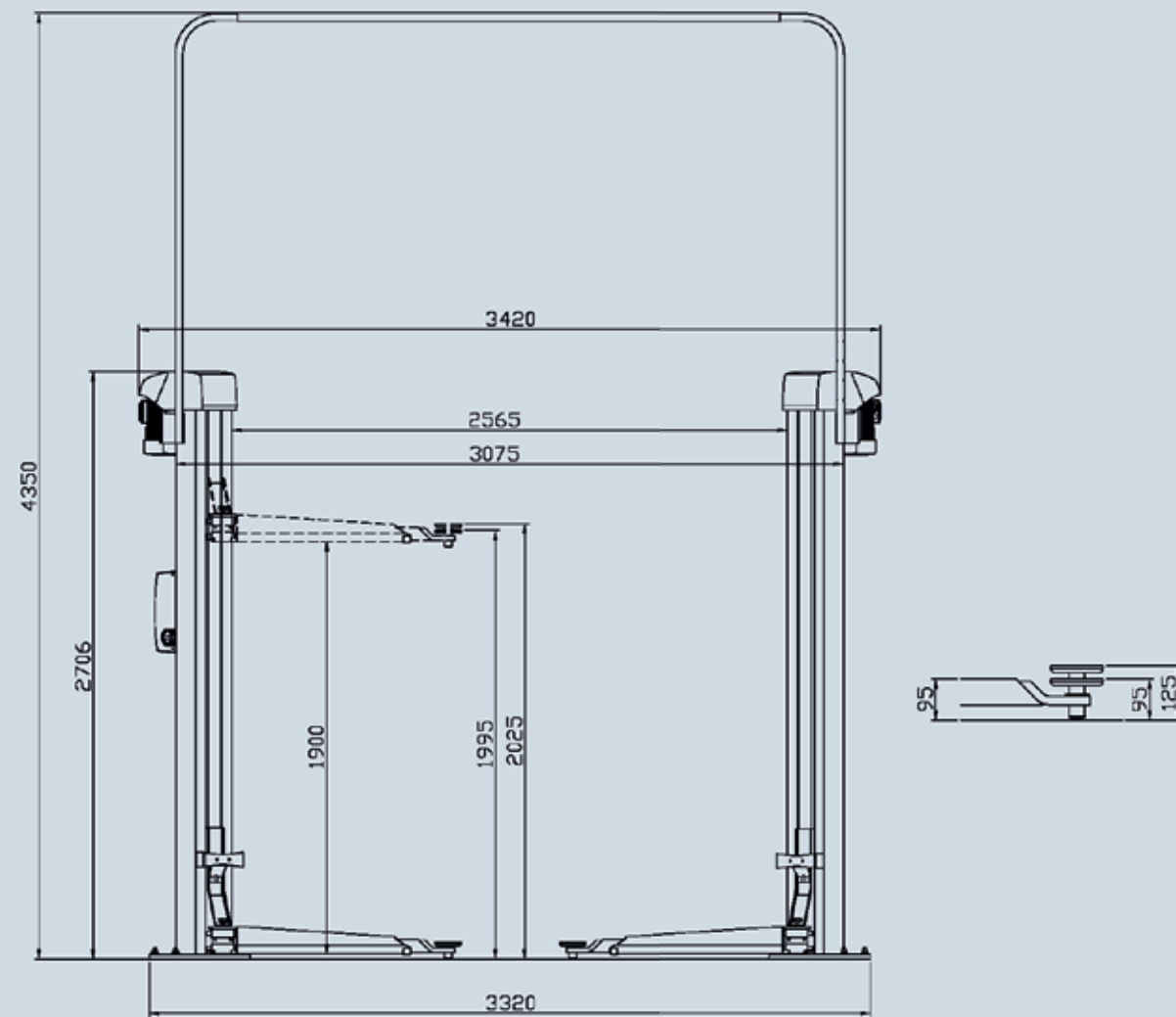

Illustrations and technical data are non-binding and may be subject to change. We reserve the right to make modifications and adjustments. Edition 12/2024



VAS 771 005A Maestro 2.35 NxT F VW

ASE77100581000

Electro-mechanical 2-post lift 3.5 t



→ Premium 2-post lift with extremely strong and welded columns for maximum stability!

The 2-post lifts of the Maestro 2.35 NxT series impress with their premium construction.

They come with extremely stable and welded columns.

Smooth running behaviour is ensured by the roller-bearing carriage.

The cold-rolled spindle guarantees a particularly long service life.

The columns are asymmetrically positioned, i. e. vehicles can be positioned far to the rear, which ensures an optimal door opening angle.

Of course, **VAS 771 005A | Maestro 2.35 NxT F VW** also has a door stop protection to prevent damage during entry and exit.

The swivel arms are extremely flat and thus ensure a low minimum height. The internal arm locking system with strong 360° interlocking protects against moisture and dirt.

Standard colour:

Arms: RAL 7040

Posts: RAL 7012

Options:

Available with different portal heights

LED lighting set

Extra control unit for second column

Wheel support devices

Large program of extra pads, depending on type of vehicle

Variants:

Available for different voltages

F = flex pad

Scope of delivery:

VAS 771 005A | Maestro 2.35 NxT F VW

ASE77100581000

Order no.	Item no.	#	Part of the approval
20012138	098470	1	Maestro 2.35 NxT F DT/ST 400/3/50 - 4350/5050mm- Ø50 pick-up, with 4 double telescopic lifting pads 16007
	777958	1	Portal set (3990-4350 mm)
	777907	1	Power pack for Maestro, 1 x Schuko plug (230 V), 1 x compressed air quick coupling 1/4"
	11104	1	Set of 2 magnetic tool trays

VAS 771 005A

Maestro

2.35 NxT F VW

ASE77100581000

Technical data

Lifting capacity	3500 kg
Stroke length	1900 mm
Working height	1987 - 2012 mm
Lifting/Lowering time	~ 35 sec.
Motor	2 x 2,8 kW
Voltage	2x 230/400V - 50 Hz - 25 A

Arm superstructure

Lifting pad included in the delivery	F: 16007: 95 - 174 mm
Total height post	2713 mm
Total height incl. portal	4350/5050 mm
Drive-through width	2445 mm
Width between posts	2759 mm
Total width outer edges base plates	3500 mm
Total width outer edges posts	3300 mm
Arm length front, min.-max.	F Premium DT: 586 -1189 mm
Arm length rear, min.-max.	F Premium ST: 927 - 1551 mm

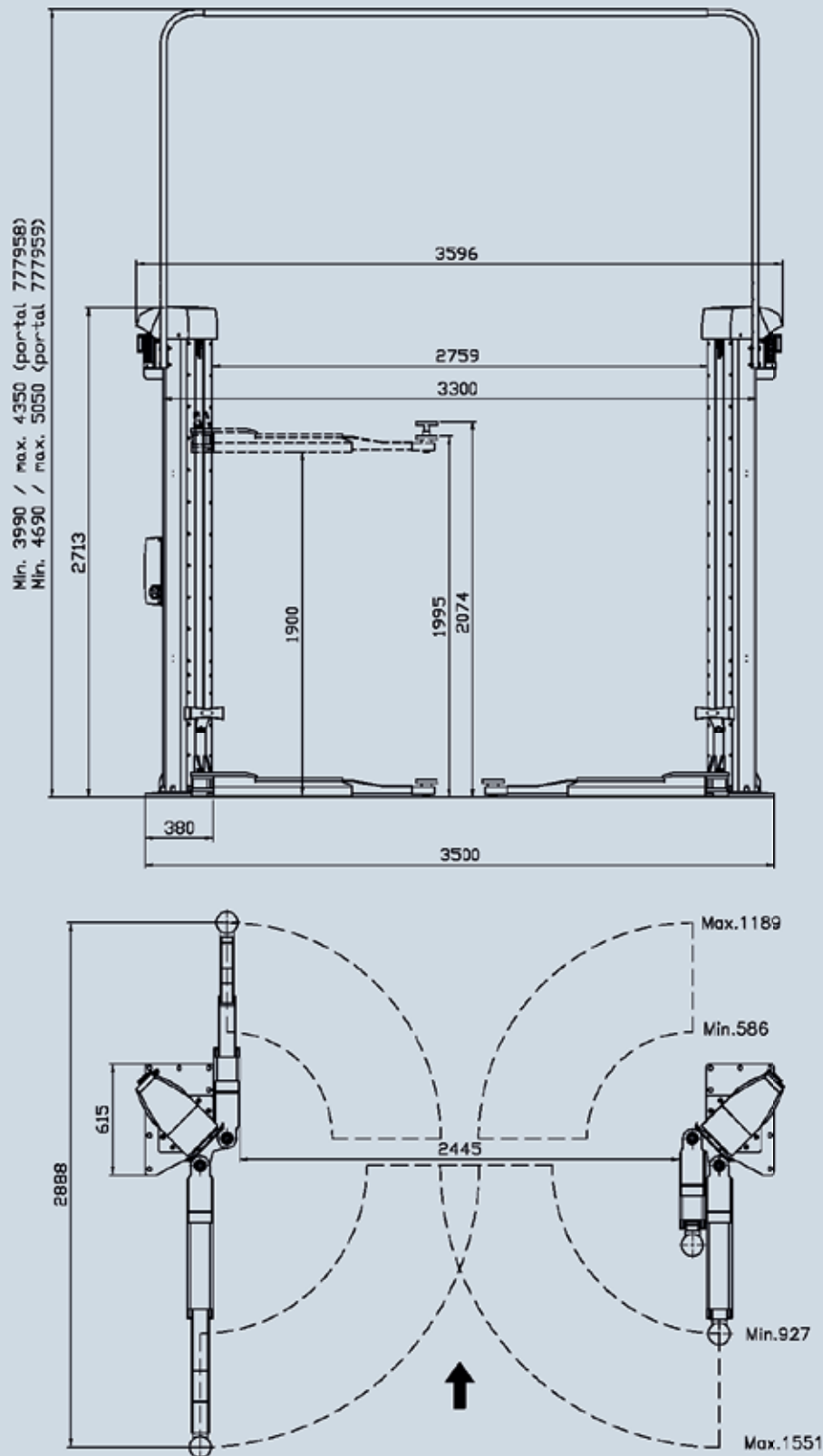

Short arm

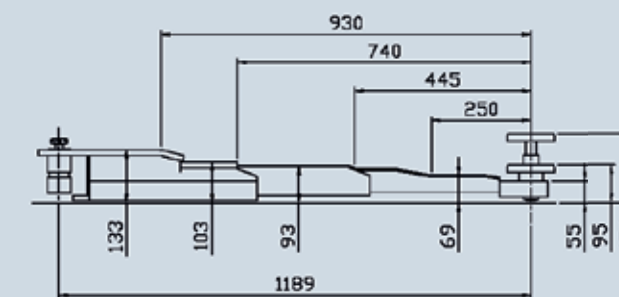

Long arm

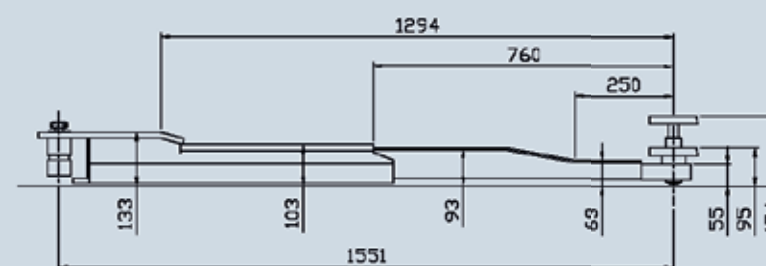

VAS 771 023A Maestro 2.60 NxT F VW

ASE77102381000

Electro-mechanical 2-post lift with 6.0 t capacity



→ The robust 2-column lift for heavy vehicles – stable, durable and perfect for commercial vehicles!!

The 2-post lifts of the Maestro 2.60 NxT series impress with their premium construction. They come with extremely stable and welded columns. Smooth running behaviour is ensured by the roller-bearing carriage. The cold-rolled spindle guarantees a particularly long service life. The welded and symmetrically positioned columns of the **VAS 771 023A I Maestro 2.60 NxT** are ideal for the safe lifting of large and heavy vehicles up to a maximum of 6 tonnes, even with difficult lifting points. The universal lifting range allows all vehicles to be lifted safely, from small cars to long-wheelbase vans. Thanks to the flat swivel arm design and the newly designed base plate, even lifting low vehicles is a simple matter, as the swivel arms reach the ground.

Standard colour:

Arms: RAL 7040
Posts: RAL 7012

Options:

LED lighting set
Extra control unit for second column
Door stop protection
Large program of extra pads, depending on type of vehicle

Variants:

Available for different voltages
F = flex pad

Scope of delivery:

VAS 771 023A I Maestro 2.60 NxT F VW
ASE77102381000

Order no.	Item no.	#	Part of the approval
20012139	004794	1	Maestro 2.60 NxT F DT/DT 400/3/50 incl. portal set - 5245mm- Ø50 pick-up, with 4 single telescopic lifting pads 16008
	777907	1	Power pack for Maestro, 1 x Schuko plug (230 V), 1 x compressed air quick coupling 1/4"
	11104	1	Set of 2 magnetic tool trays

VAS 771 023A

Maestro

2.60 NxT F VW

ASE77102381000

Technical data

Lifting capacity	6000 kg
Stroke length	1900 mm
Working height	2000 - 2045 mm
Lifting/Lowering time	~ 55 sec.
Motor	2 x 2,8 kW
Voltage	3x230/400 V-50Hz - 35/25A

Arm superstructure

Lifting pad included in the delivery	F: 16008: 98 - 145 mm
Min. height	98 mm
Total height post	2912 mm
Total height incl. portal	4885 - 5245 mm
Drive-through width	2838 - 3038 mm
Width between posts	3238 - 3438 mm
Total width outer edges base plates	4000 - 4200 mm
Total width outer edges posts	3627 - 3827 mm
Arm length front & rear, min.-max.	F DT/DT: 906 - 1926 mm

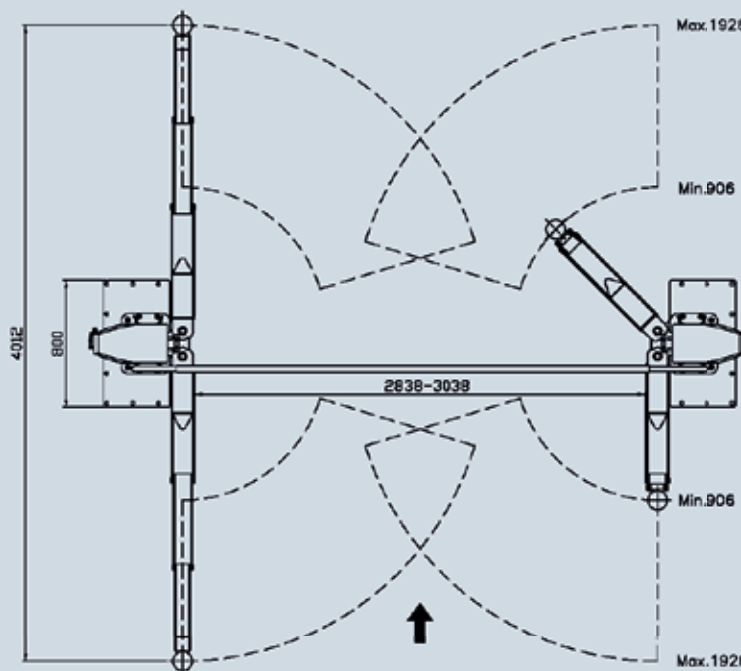
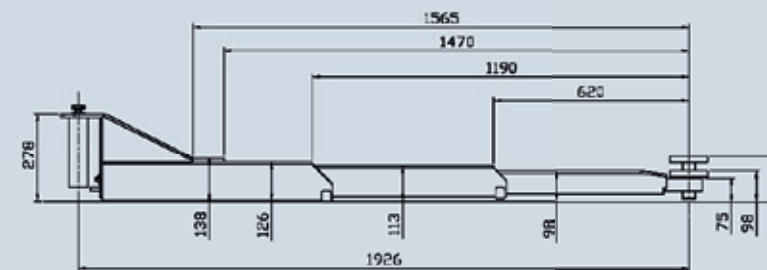
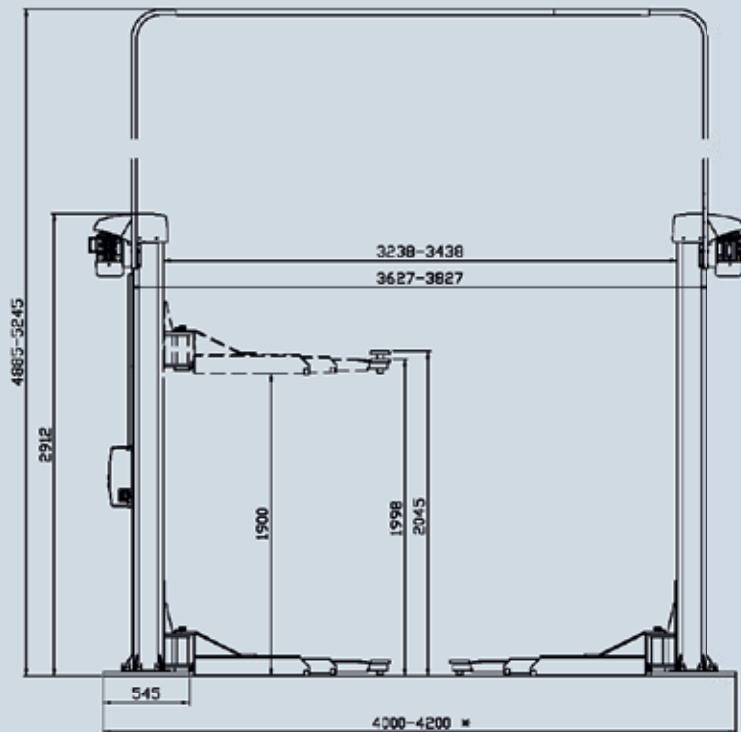

*)
4.000mm recommended for focus on lifting transporter
4.200mm recommended for universal lifting area / more focus on passenger cars



We are the global competence center for workshop equipment within the Volkswagen Group.

With our products and services, we enable our customers to offer professional and resource-saving maintenance and repair services.

Through innovative and partnership-based cooperation With the development departments of the Group brands and our suppliers, we develop sustainable and intelligent technical solutions for all requirements.

We create
service readiness
at factory standard level.

The high quality, durability and versatility of our workshop equipment a high level of investment protection and efficient resource management in the process of service delivery.

Together we bring vehicles quickly and sustainably back to where they belong:
on the road.

Thus, we make a significant contribution to maintaining the value of the vehicle fleet over generations of vehicles throughout the world.

This is what our brand
stands for with
the seal of approval.





AUTOPSTENHOJ GmbH
Sandkampstraße 90
D-48432 Rheine
www.autopstenhoj.com
E-Mail: info@autopstenhoj.com
Tel. 05971-860202

Technische Änderungen vorbehalten
Stand 09/2024